

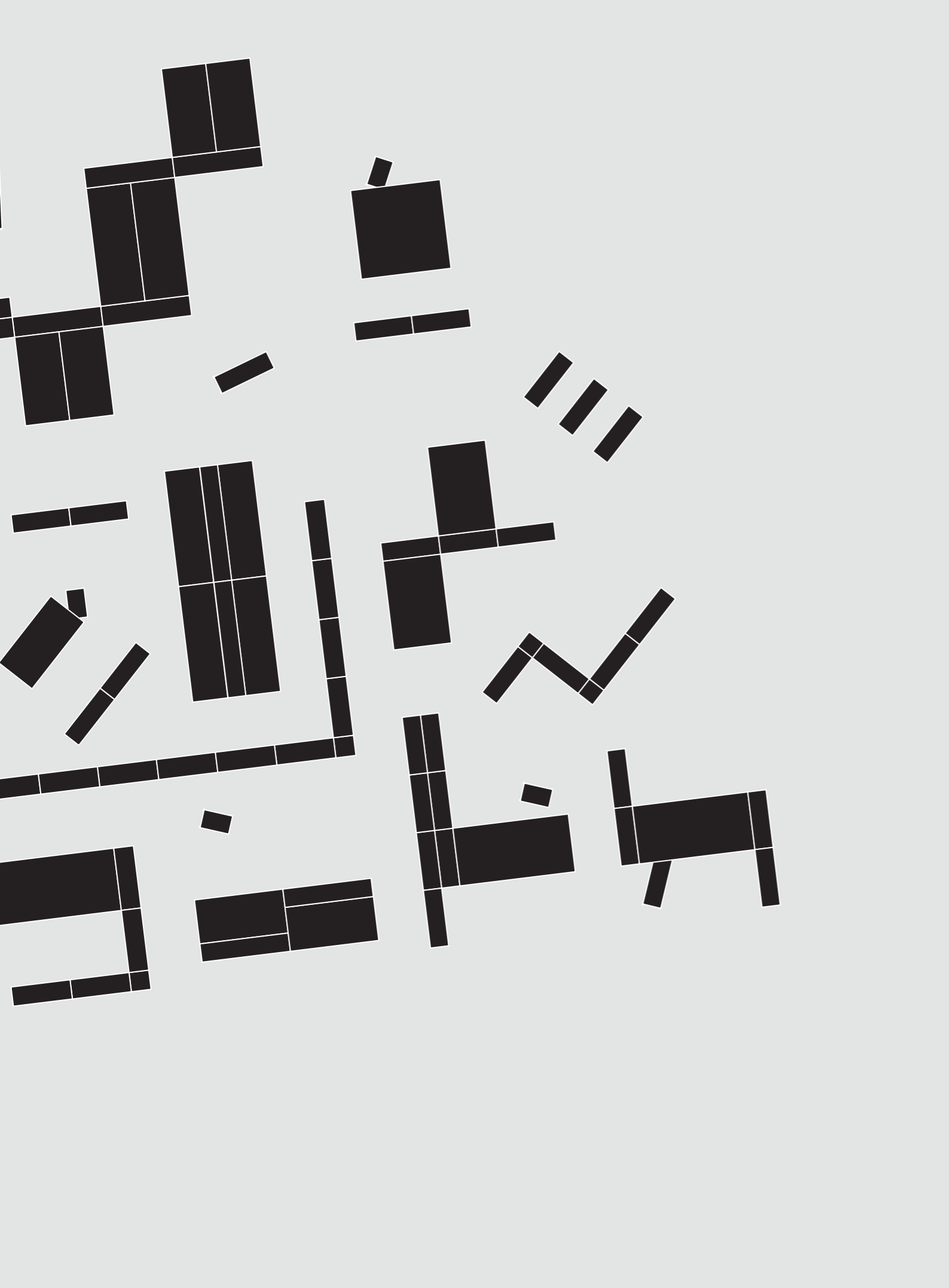

**NEW ORDER**  
**Workspace Elements**

**HAY**



NEW ORDER by Stefan Diez

## **NEW ORDER**

### **Workspace Elements**

*Times are changing - and so is the way we store our lives. Rather than stacks of paper and rows of ring-binders we now store our information in digital clouds, neatly organized alongside thousands of photos, music, and films.*

*The digital age had an impact beyond the area it revolutionized, including our relationship to architecture and furniture. Boundaries keep on blurring, bracing the ongoing revolution in our every day life thanks to a continuing miniaturisation of digital devices and a powerful global data infrastructure.*

*With contemporary solutions fitting the needs of our generation, Hay plans on being a vital part of this enterprise.*

*After presenting the shelving and storage system New Order, with a primarily domestic environment in mind, we are now introducing a range of extensions supporting New Order's potential in the world of workspaces, making it a high-precision product with exceptional properties and providing an impressive versatility.*

## SHELVES



## ARCHITECTURE

*New Order functions as a space-dividing and space-creating system, while at the same time organizing the space in between. New Order's grid with its up to 2 meters long shelves and trays let you build airy, open compositions or closed constructions with sliding doors and drawers. By adding side and back panels, wall-like expressions are created, with the closed cabinets taking on a visual substantiality.*

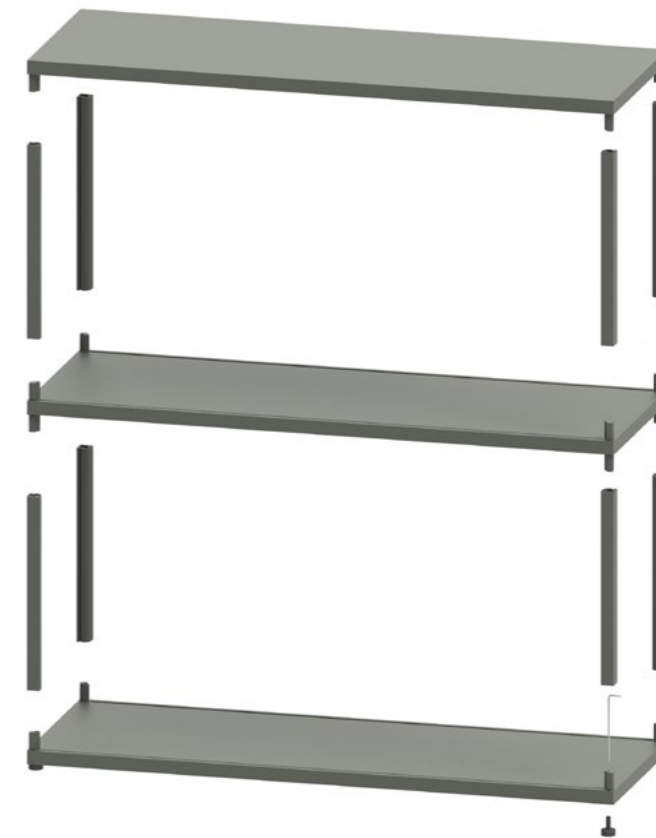

## TRAYS

*New Order trays are a contemporary alternative to shelves, especially for storing or displaying all sorts of smaller or larger objects. A large array of accessories broaden the tray's potential in the office environment.*

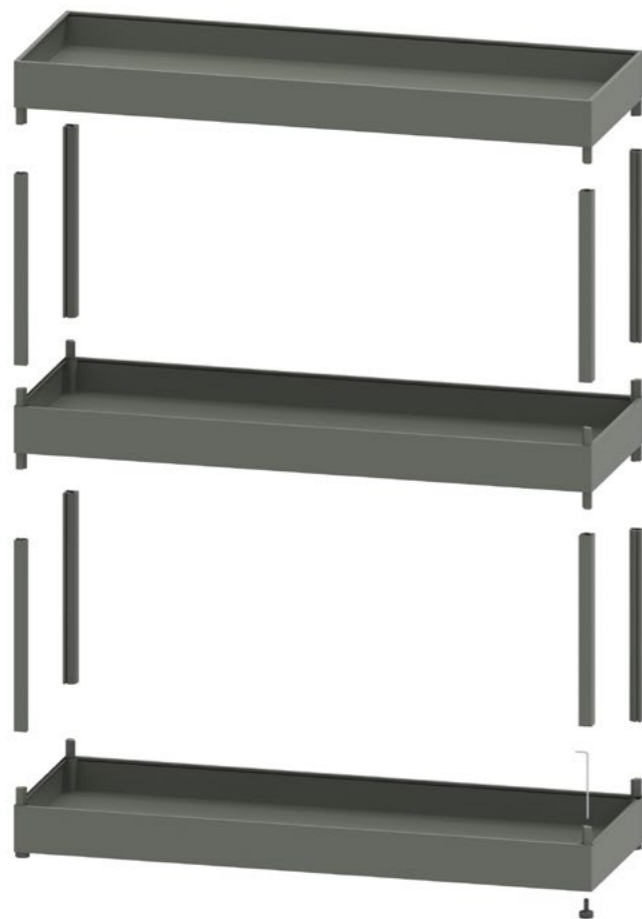

Same profiles are used for both shelves and trays



SINGLE PROFILE



Building up shelving elements

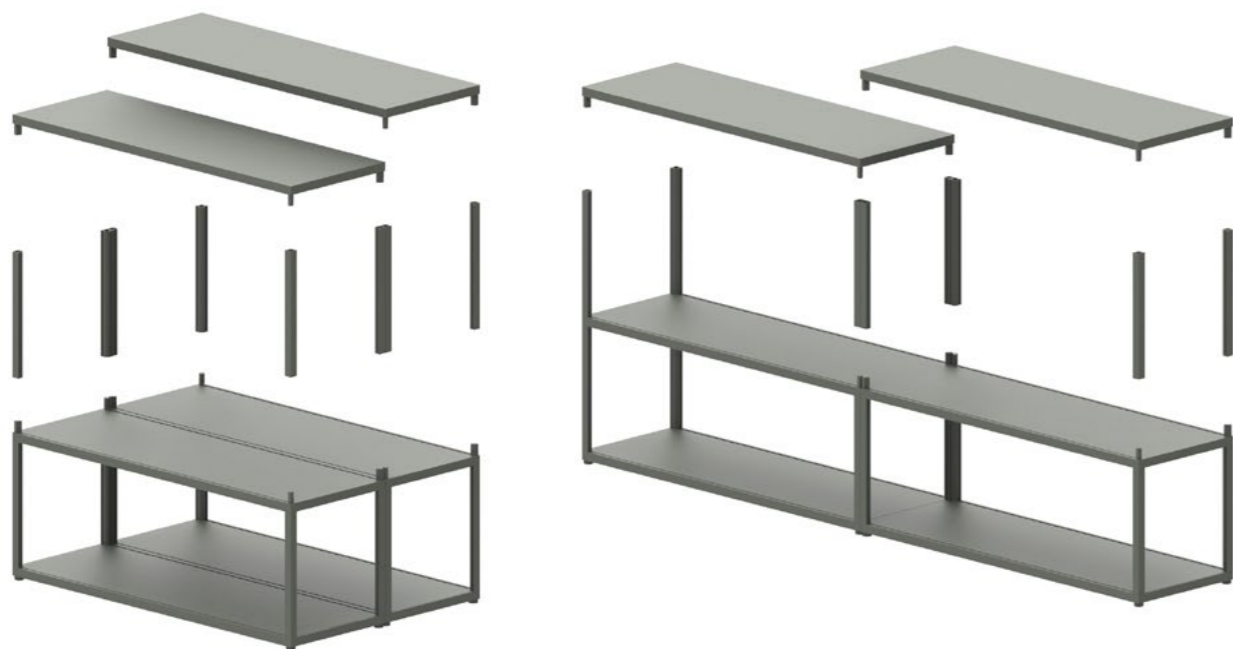

DOUBLE PROFILE

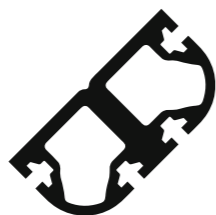

Connecting shelves along the length and the width



## PANELS

*The simple, graphic grid of New Order is almost ascetic.  
Adding back and side-panels, the system takes on  
substance as the unit gradually closes up.*

*New Order is born of 100% industrial production, reflecting  
our ambition to create uncompromising quality products.  
The side and back-panels are mounted from the front,  
which allows New Order to be assembled directly in front of  
a wall or corner. This proves to be a great advantage  
with uneven floors or heavy setups.*

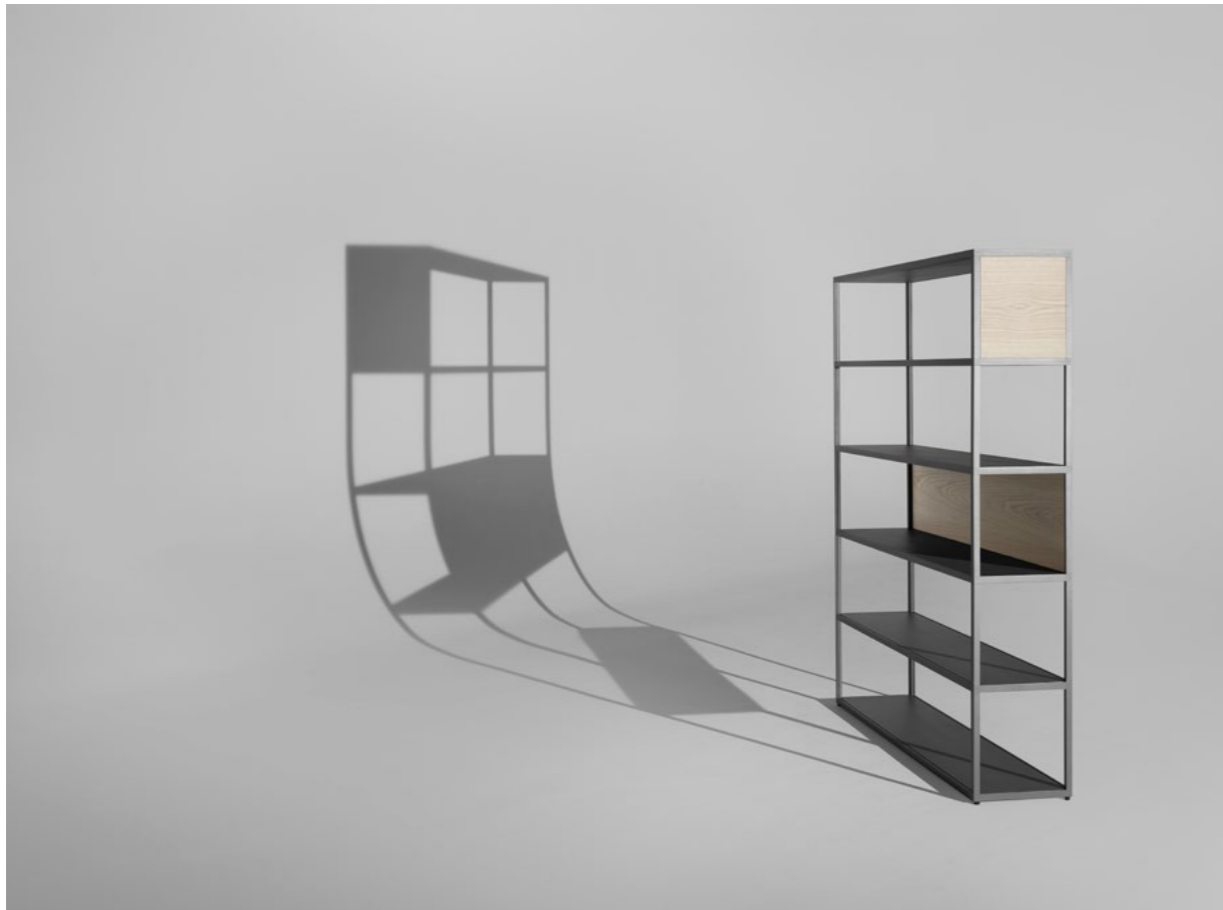

Panels can be mounted onto any side

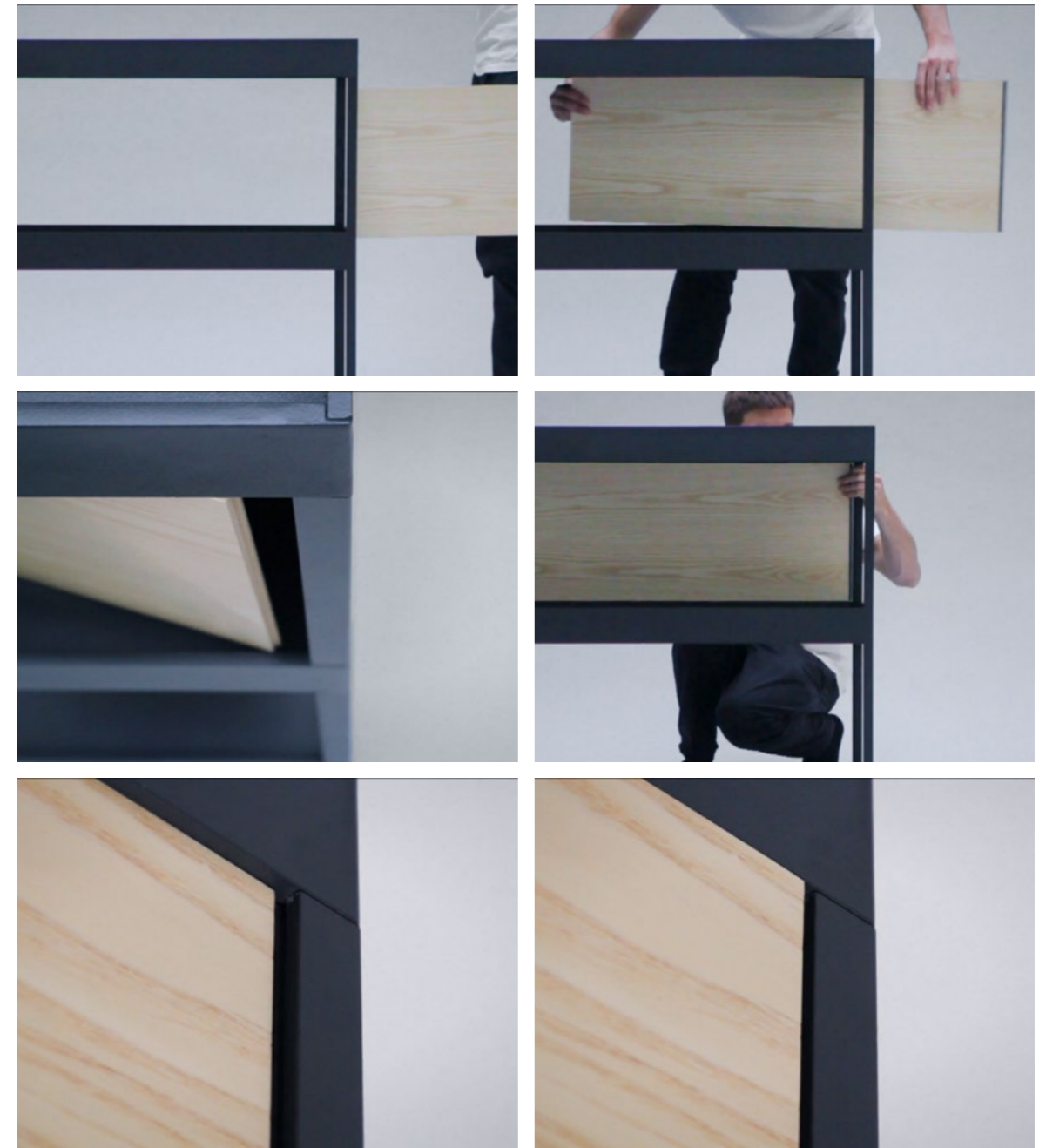

Polypropylene fittings allow the panels to be clipped into the frame

## ACOUSTIC PANELS

*Side and back-panels are available in natural or stained wood. Textile covered acoustic panels reduce environmental noise and offer the opportunity to play with texture and a large variety of colors. Acoustic panels simultaneously serve as pin-boards in both domestic and office environments and thus supports the architectural aspiration of New Order.*

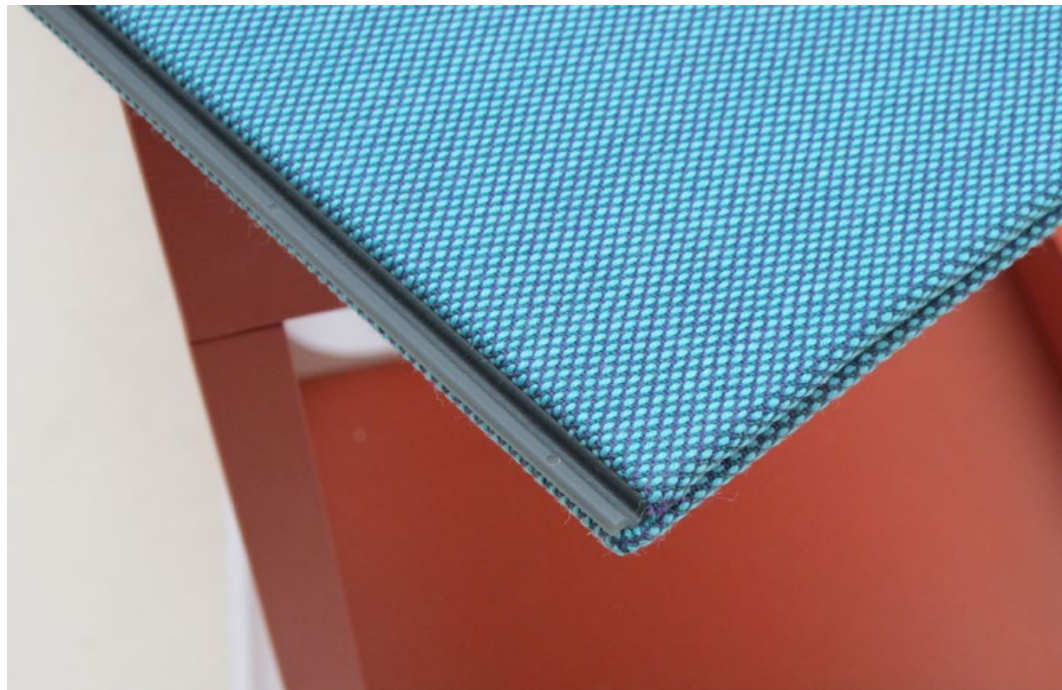

Acoustic panel in upholstered fabric





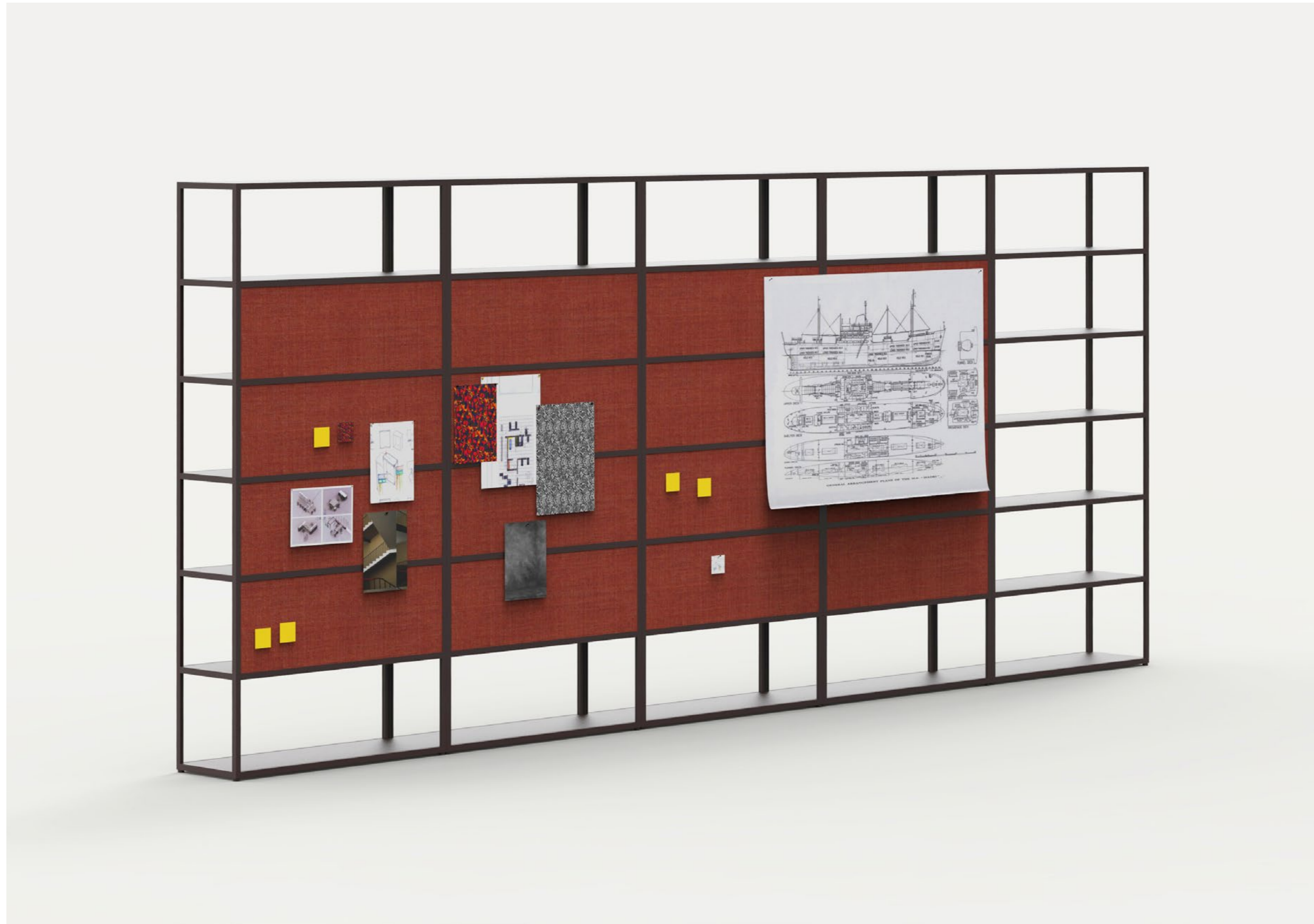

Upholstered acoustic panels used as a pinboard wall

## DOORS &amp; HINGES

*The high-precision engineered hinges are virtually invisible thanks to their lightweight design. Like the panels, the sliding doors are designed to be clicked into place without the use of tools.*

*New Order is the flexible lightness of storage in a durable form. No amount of clutter behind the cabinet doors will make the slightest impression on the clean minimalist exterior.*



The handles are exchangeable to either fit the colour of the panels or the frame.



*Shelves and trays come in standard lengths of 34, 100, 150 and 200 cm. The folding door mechanism guarantees an easy access even with a 2 meter span width. On request, New Order is available in custom sizes to fit the architectural grid in office landscapes.*

Combined sliding doors open to the left and the right on wide cabinets

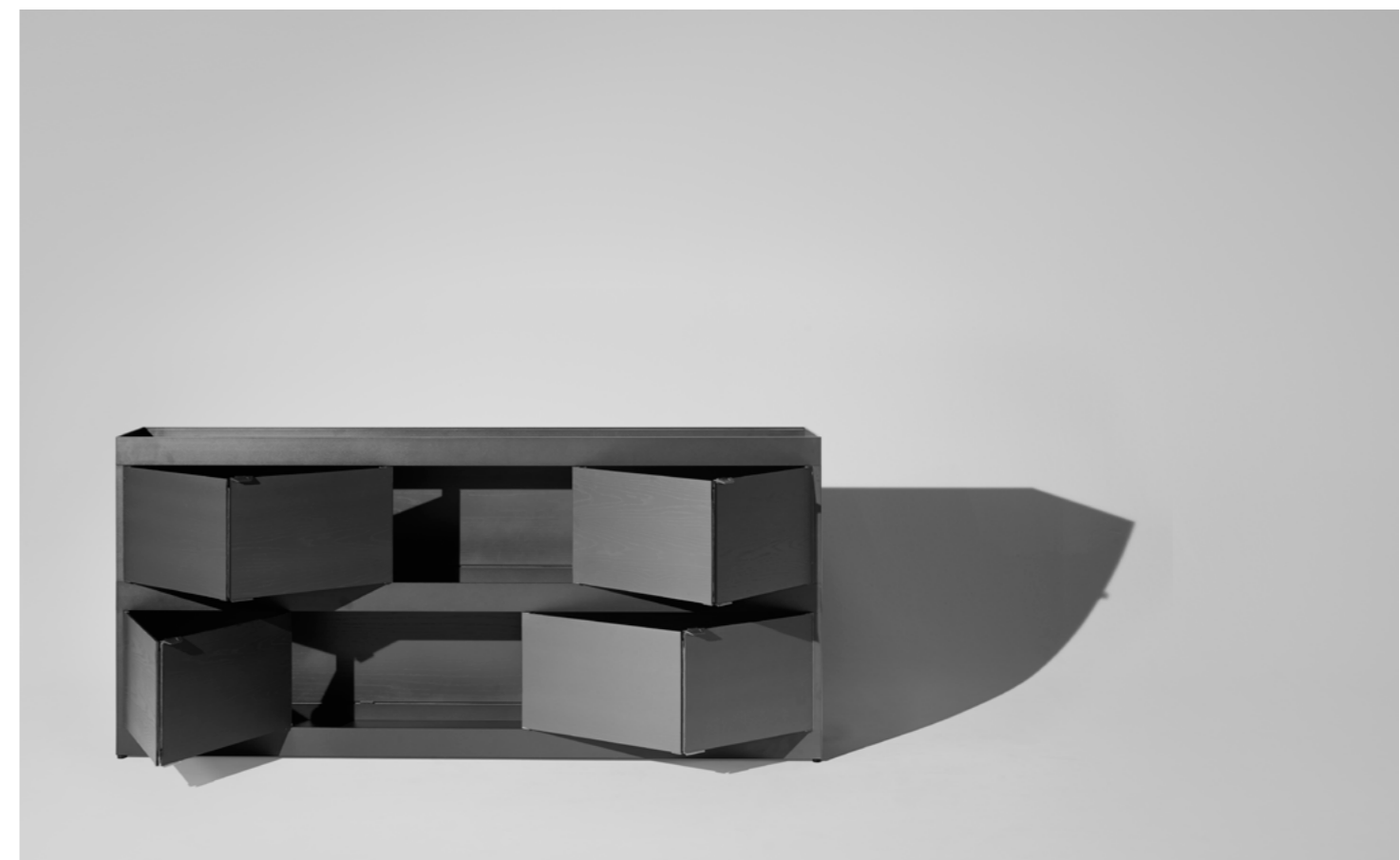



*New Order is unbiased. Panels and doors can be mounted from any direction and allow simultaneous access from all sides.*

## CORNER MODULE

*New Order's corner module combines practical and aesthetic qualities in a single design solution. The corner module allows you to build the shelving system around a corner and even build your own closed formations, or a semi-closed room within a room. The square corner module offers the same features as the other components in the system, such as the option to close sections off with doors, back-panels and side-panels. You can even build an open transparent column for display purposes, as the tray function is also available in this square format for the corner module.*

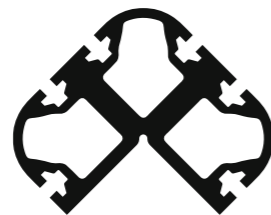
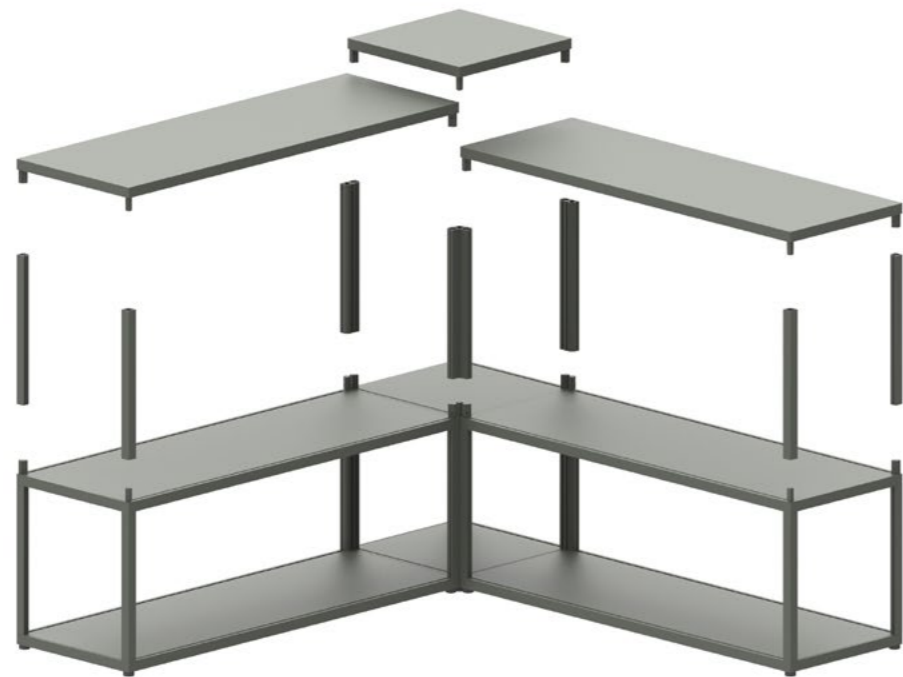

## WALL-MOUNTED

*New Order can be mounted on the wall, offering both functional storage and a visual renewal of interior space.  
A snapped-in back-panel prevents New Order from slipping out of the wall anchorage.*

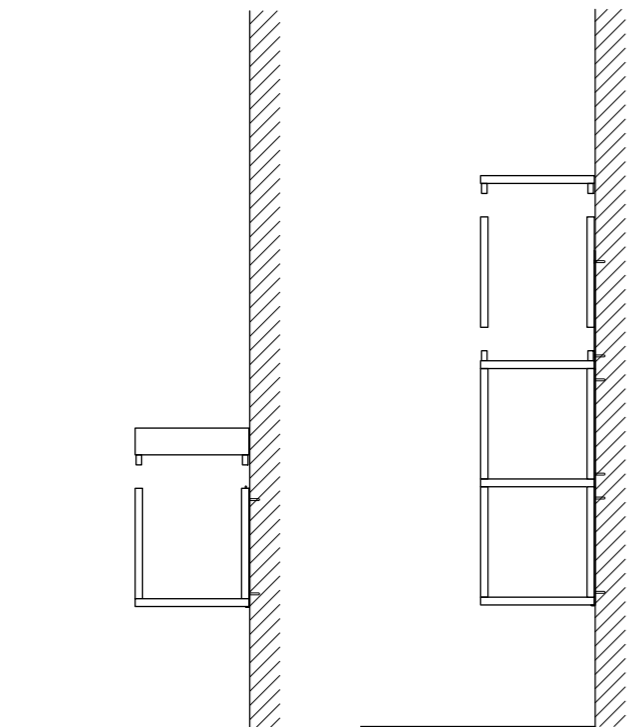

Both trays and shelves can be mounted onto the wall, with no height limitations.

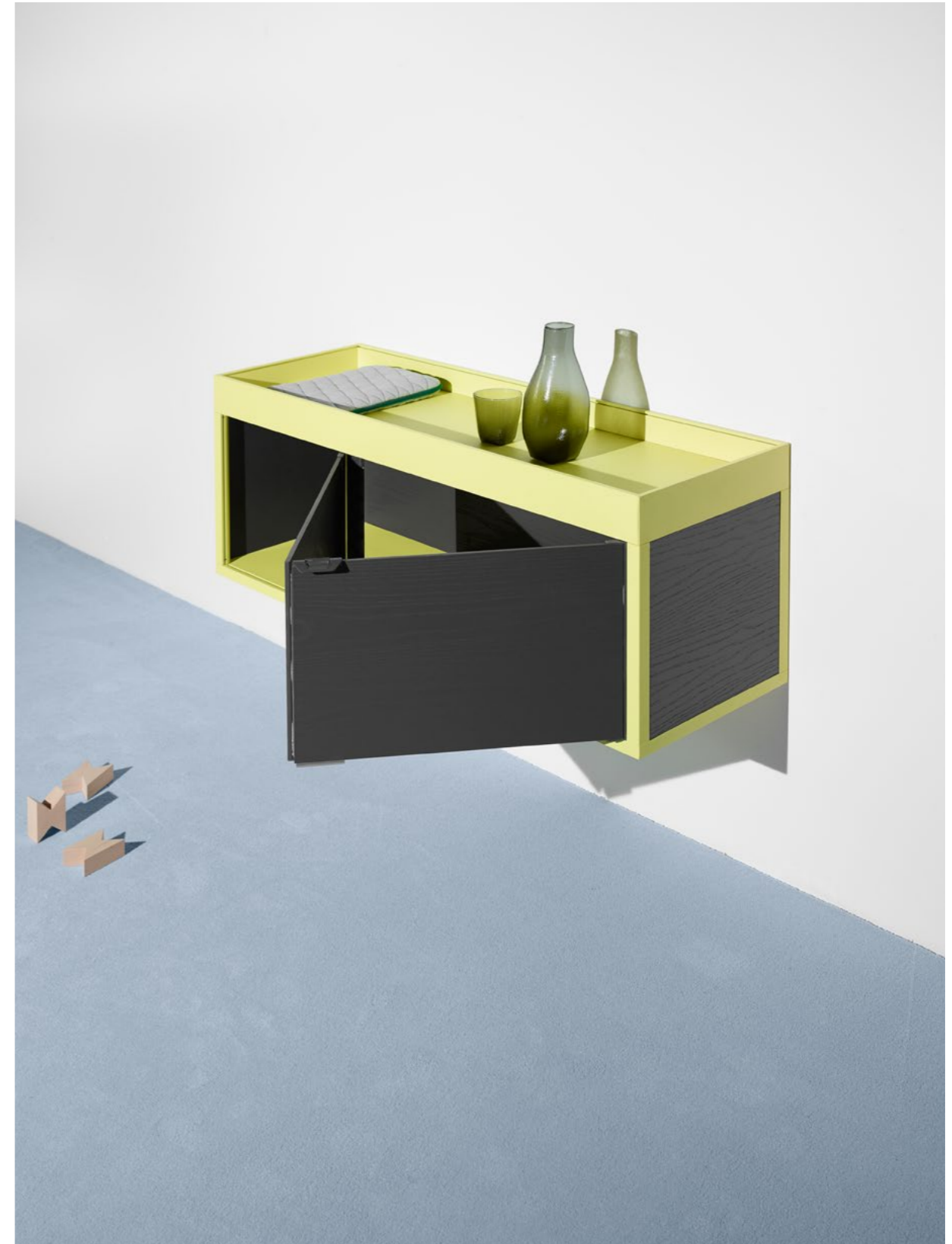

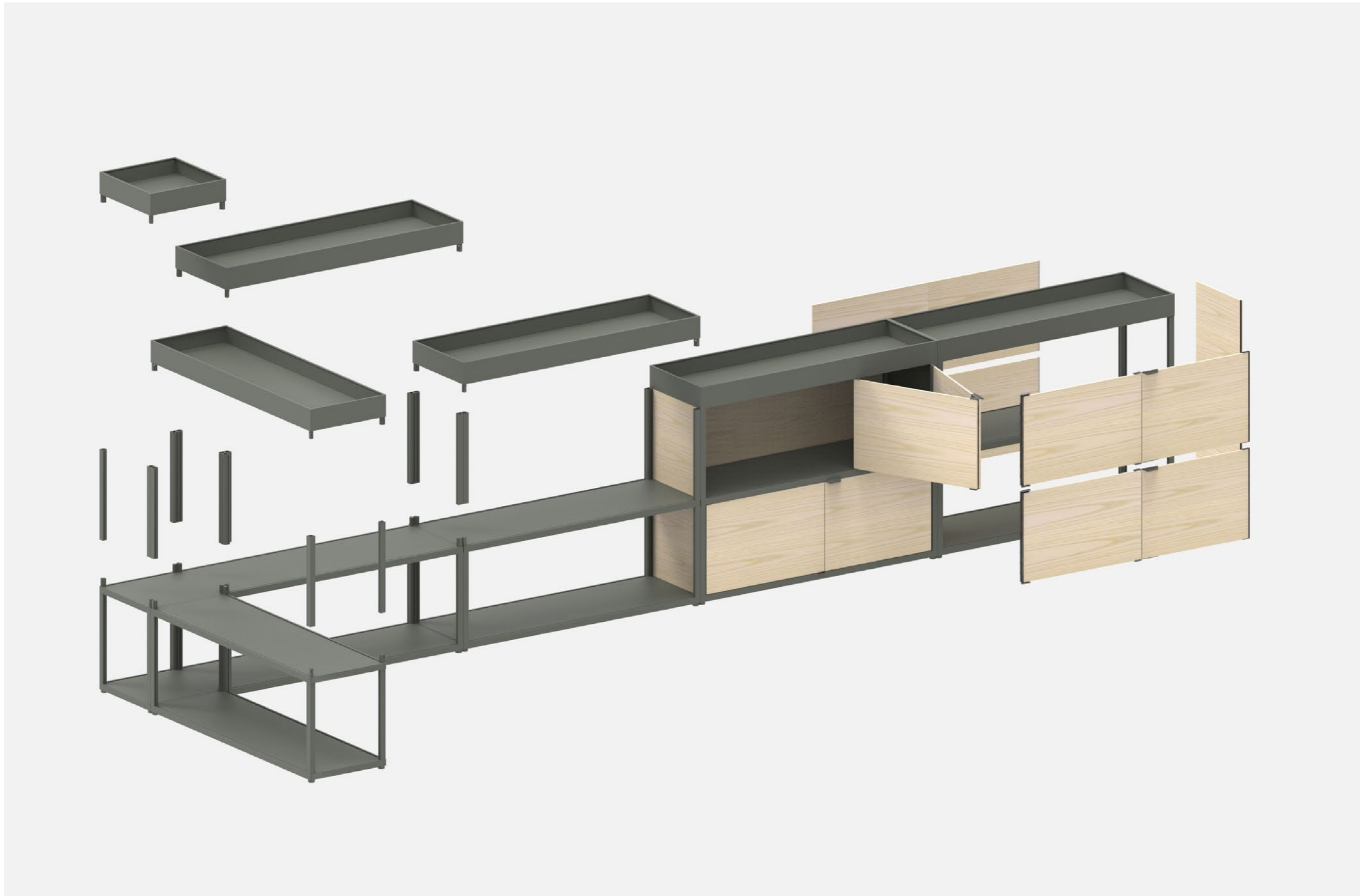

## TABLE

*Just like the vertical structure of New Order, the matching tables are built from functional aluminium profiles that are able to handle the infrastructure of cables and acoustic panels often vital for an office environment. The tables are available in various standard sizes fitting the horizontal as well as the vertical grid of New Order. Tabletops are available in natural wood, powder coated in the frame colours and in linoleum, which is soft and ideal for drawing and writing. A set of connectors expand the functionality of the tables, allowing them to directly hook onto a New Order shelf and literally merge with it.*

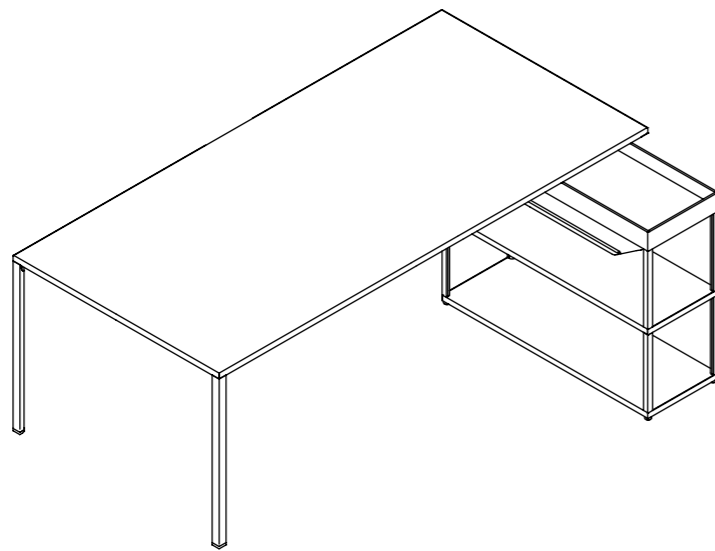



## CABLE MANAGEMENT

*A basic cable management system is integrated in the structure of each New Order table. With the help of accessories this basic feature can be extended to match versatile expectations in an office universe, but equally at home or for school and work desks.*



Tables are shipped flat packed and mounted on site.  
Aluminum profiles protect the worktop's edges in a heavy duty environment.

## SCREENS

*Acoustic partition walls can be placed onto New Order tables and thus aid in keeping the work environment quiet and private. Just like the New Order panels they can be used as pinboards, offered in cork or an upholstered covering.*



Cork screens are made of a naturally noise absorbing material

Acoustic screen is offered in upholstered fabric

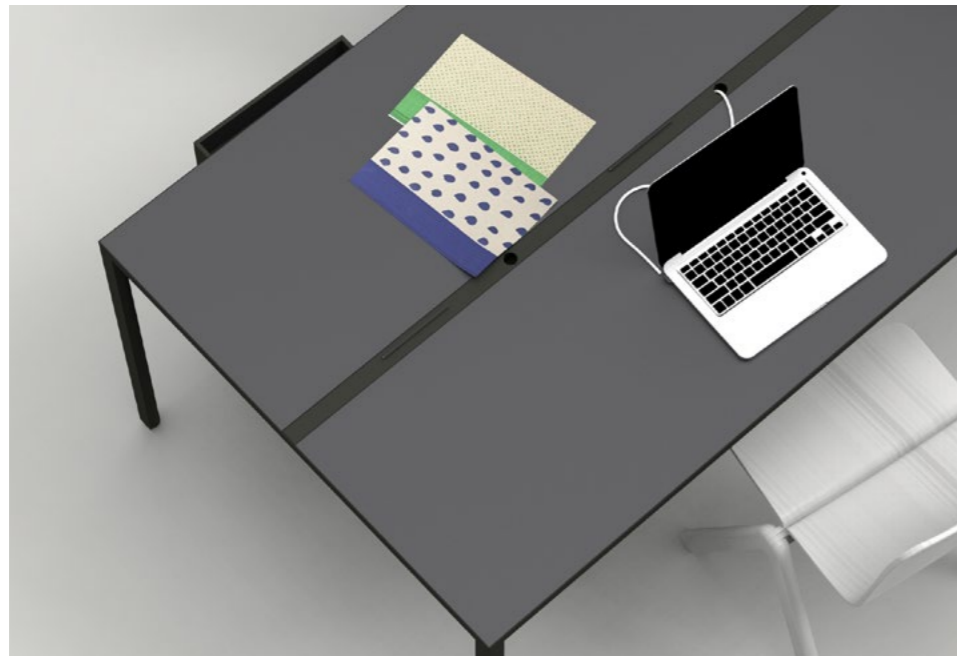

## TABLE LEGS

*Very similar to the shelving structure of New Order, tables can be joined to form bigger units with the help of double and tripple leg profiles. This is a great help to keep larger arrays of tables in a perfect order, or to create table units with a sensitive wiring.*



A set of double and tripple leg profiles combine several tables to a larger unit, which remains stable yet flexible. The tripple profile allows for L- or U-shaped combinations.



TABLE/SHELF CONNECTORS

Connectors combine New Order directly with a table, relinquishing the legs and forming a stable, rigid workstation.

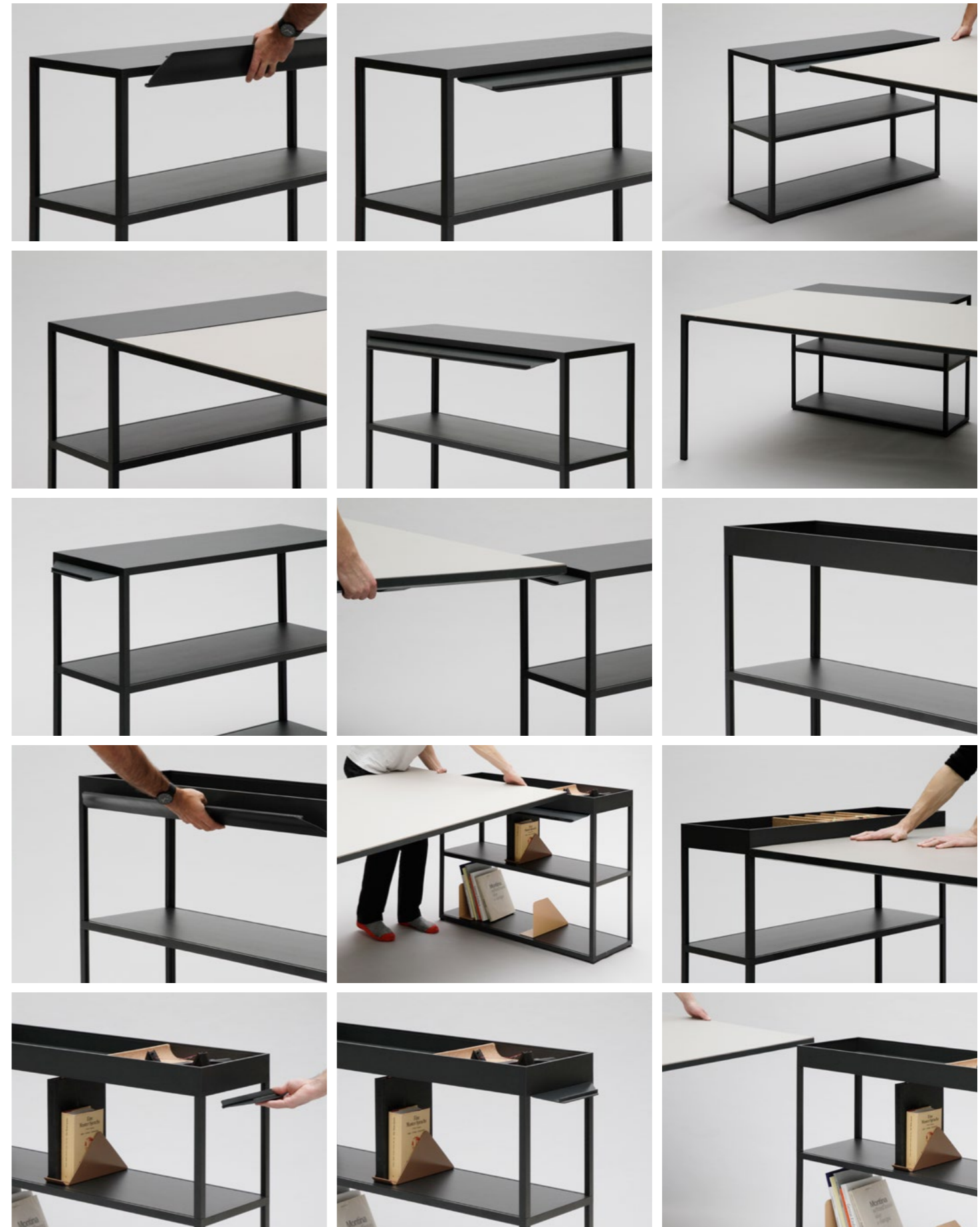
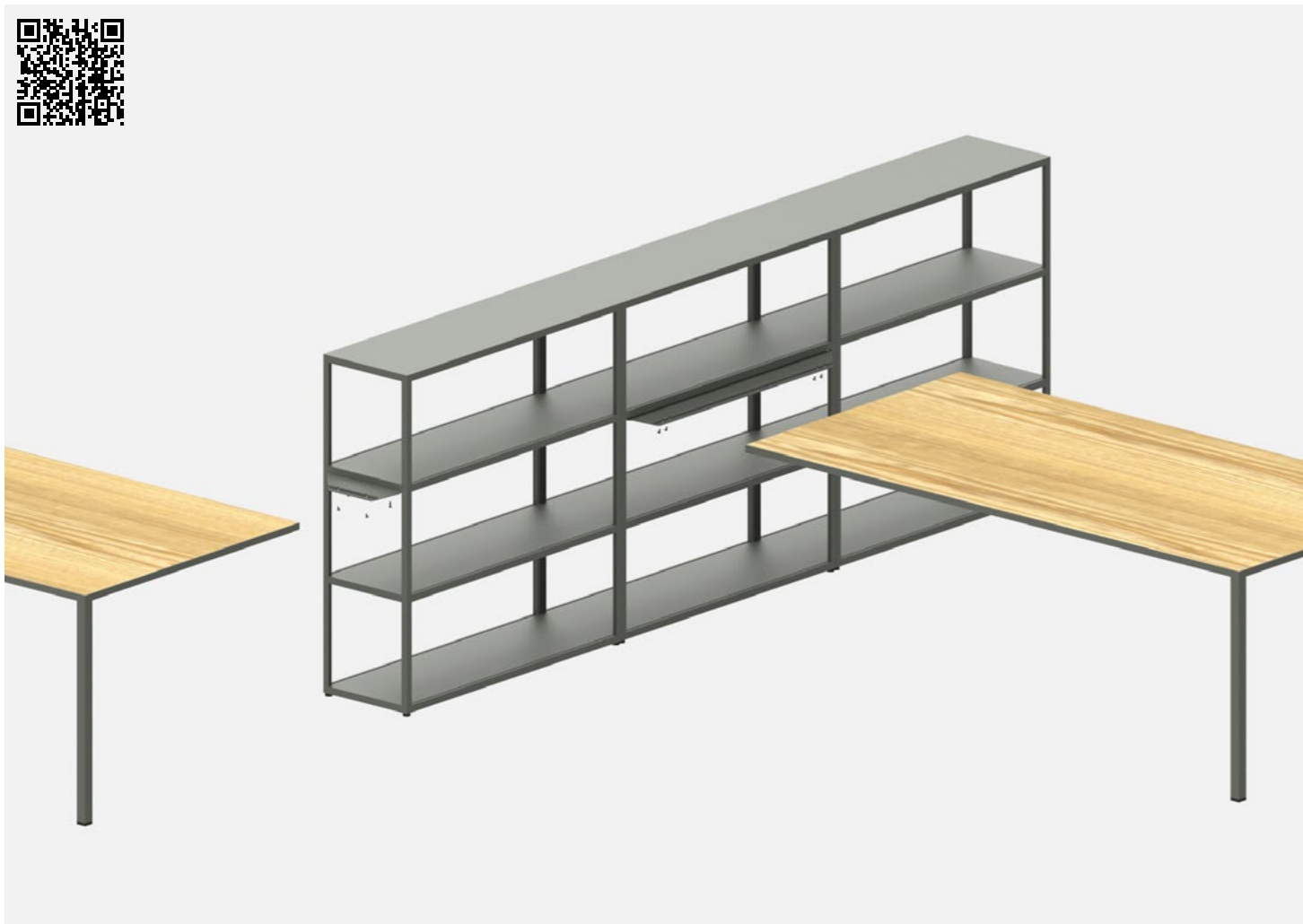

## WORKSPACE UNITS

*Shelving and storing units form the backbone of New Order Workspace Elements. Attached tables in different heights for sitting as well as standing enable an almost infinite number of customized configurations. Conventional necessities and typical architectural contexts suggest a small number of standard configurations and variations. These can be explored in detail on a related website with 2D and 3D data for a seamless integration into almost any planning software.*

[WWW.NEW-ORDER.INFO](http://WWW.NEW-ORDER.INFO)

Following top view drawings are scale 1:50

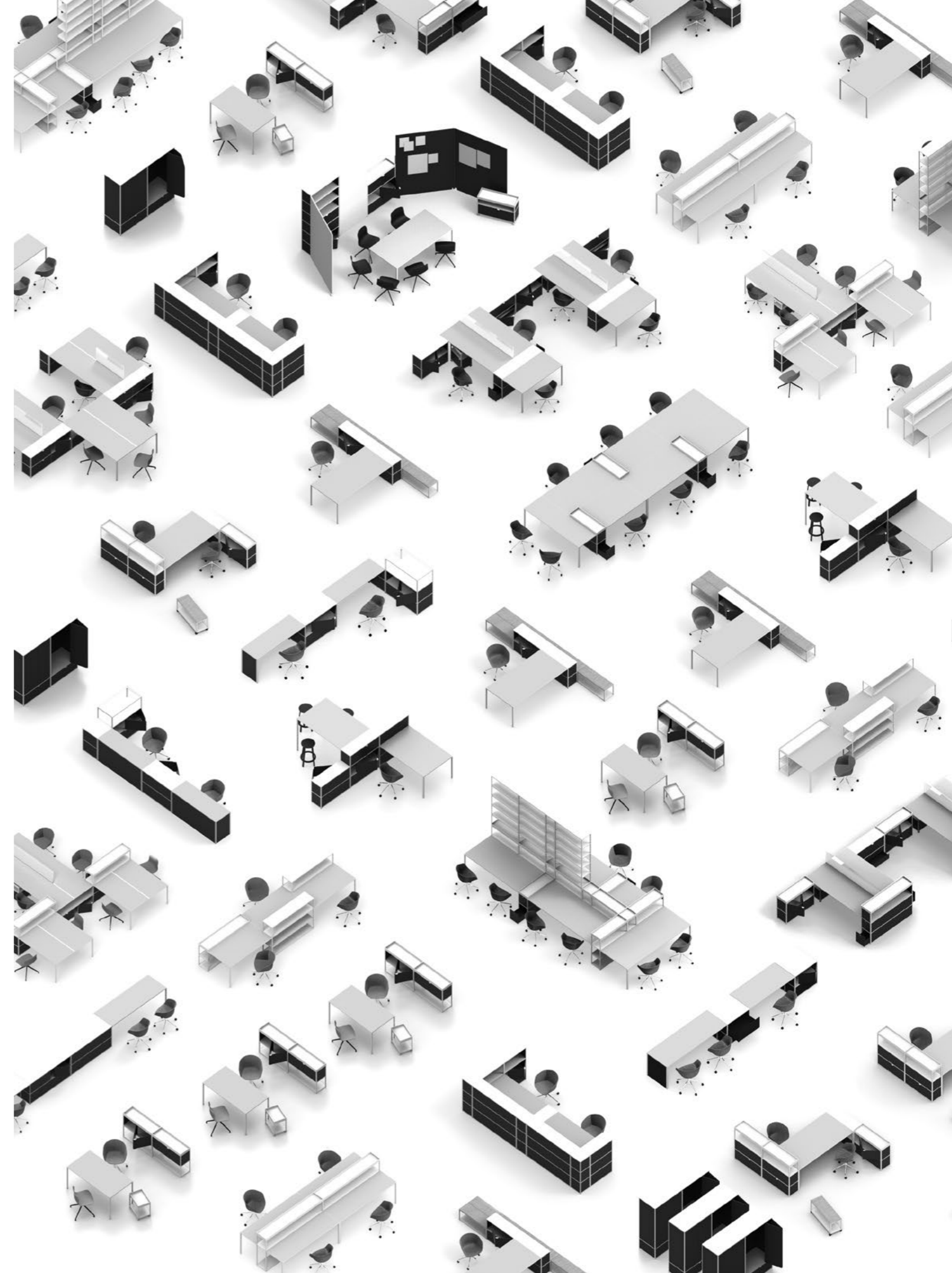

### SINGLE WORKSTATIONS

STORAGE, SPACE DIVIDER, TROLLEYS

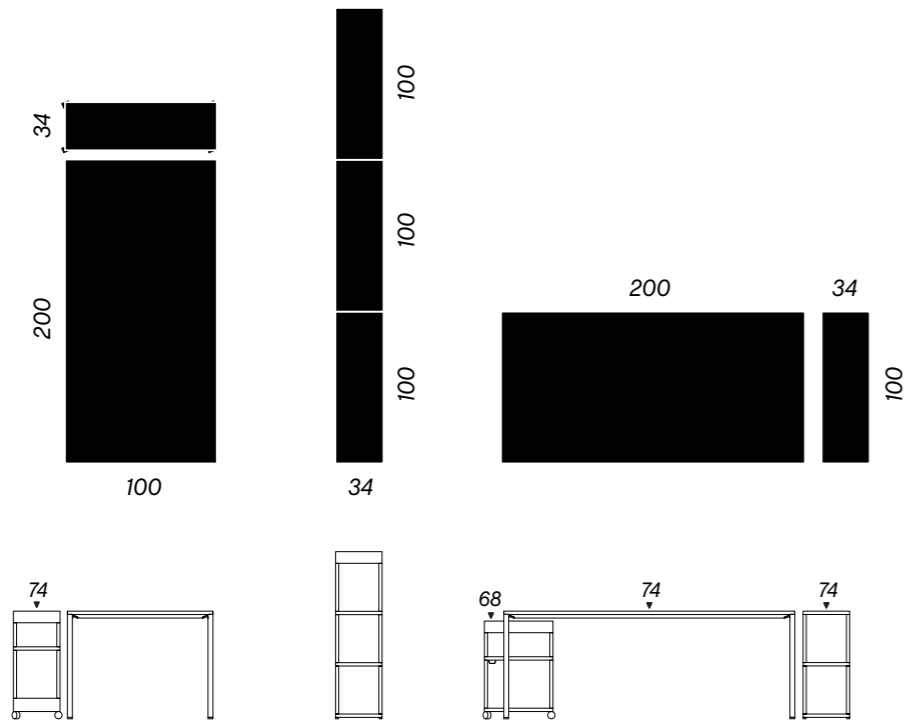

### HOOKED DESK ROW

STORAGE, TRAYS, DRAWERS, TROLLEYS

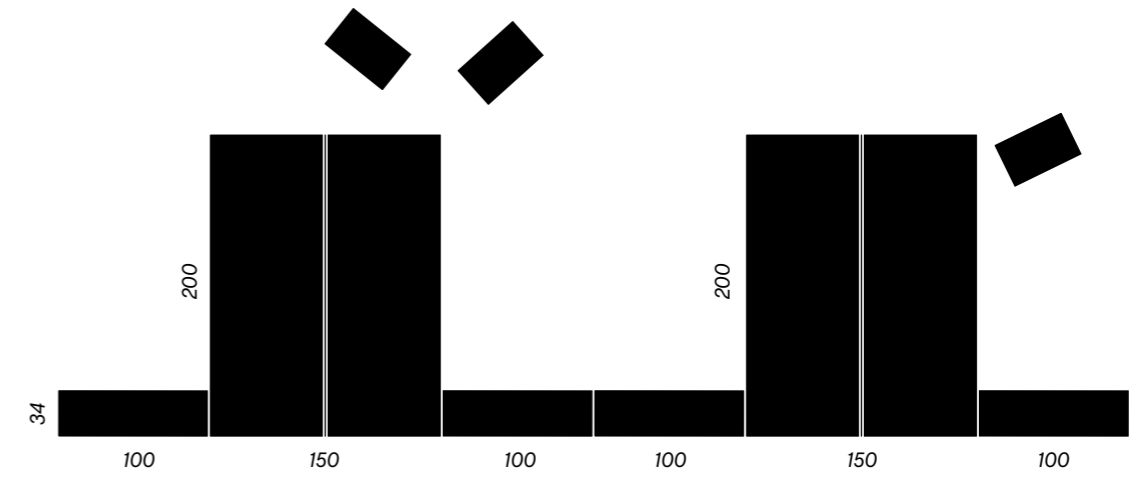

### COUNTER ISLAND

INFORMAL MEETING, STORAGE, STANDING WORKPLACE

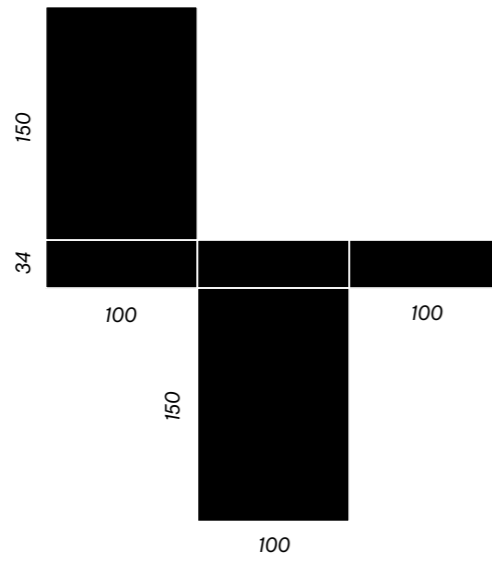

### HIGH TABLE

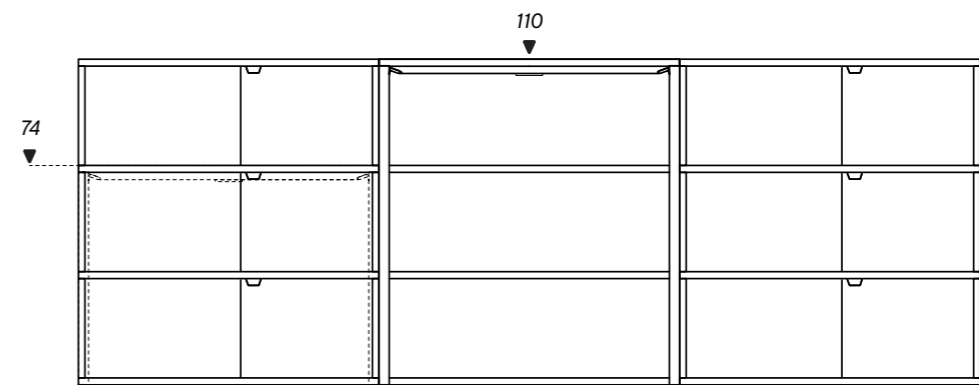

### IRREGULAR WORKSTATION

SPACE CREATING, COLLABORATIVE WORKING, ONE LEVEL

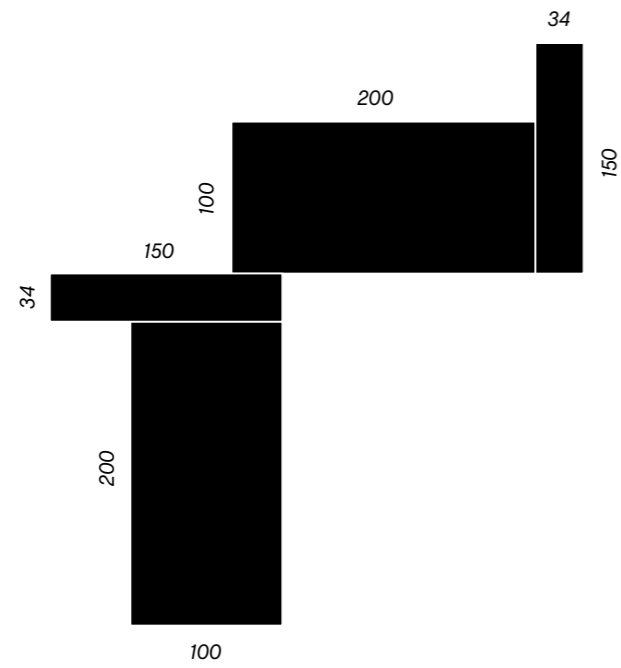

### WALL-MOUNTED WORKSTATION

SPACE SAVING, WINDOW SETUP, STORAGE

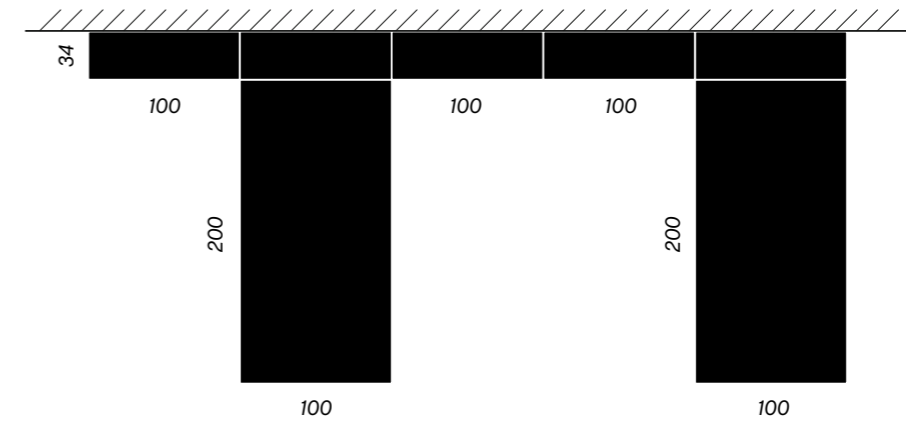

In combination with a wall mounted New Order setup, tables create a highly functional, yet elegant workspace unit, for example directly under a window front.

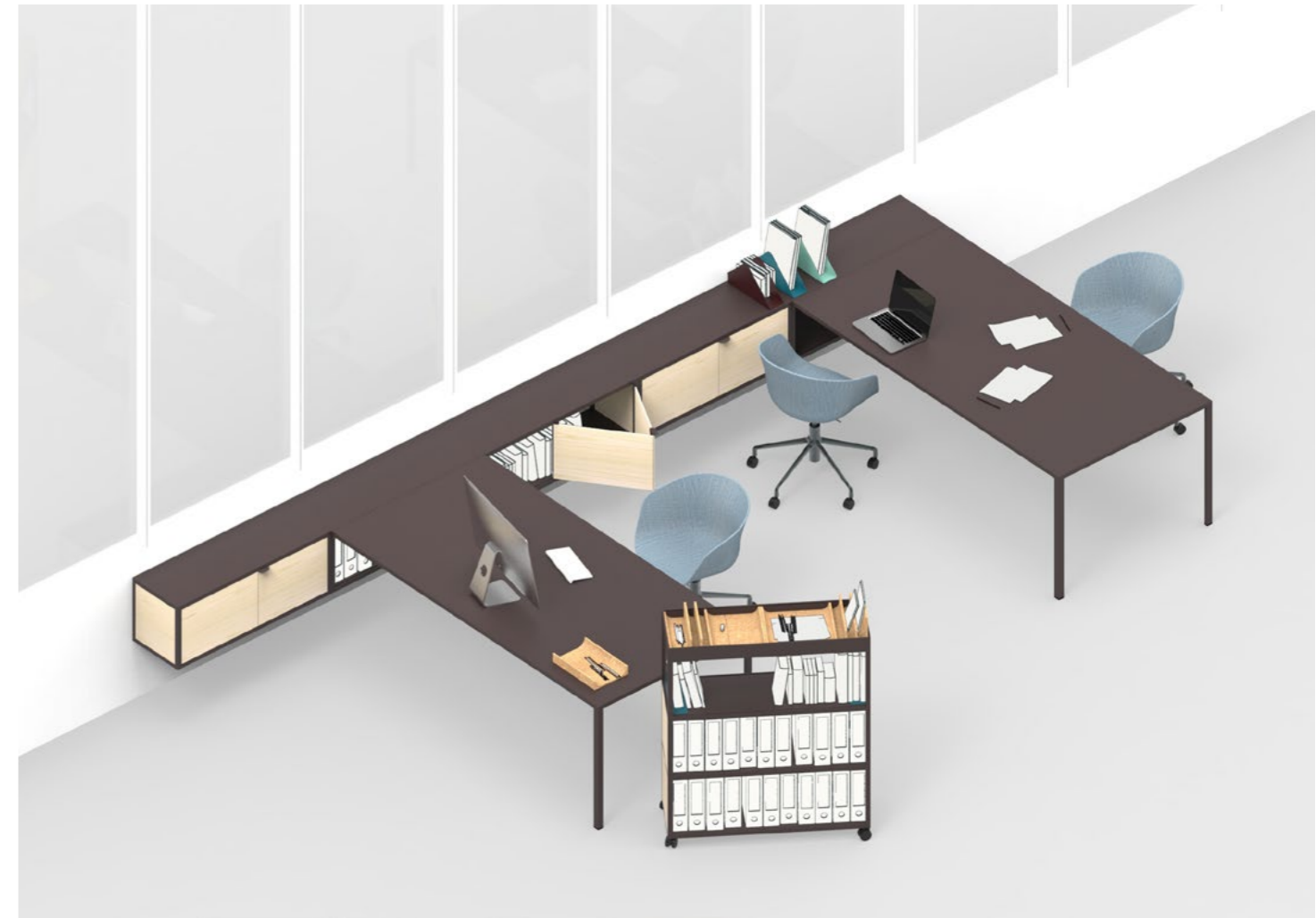
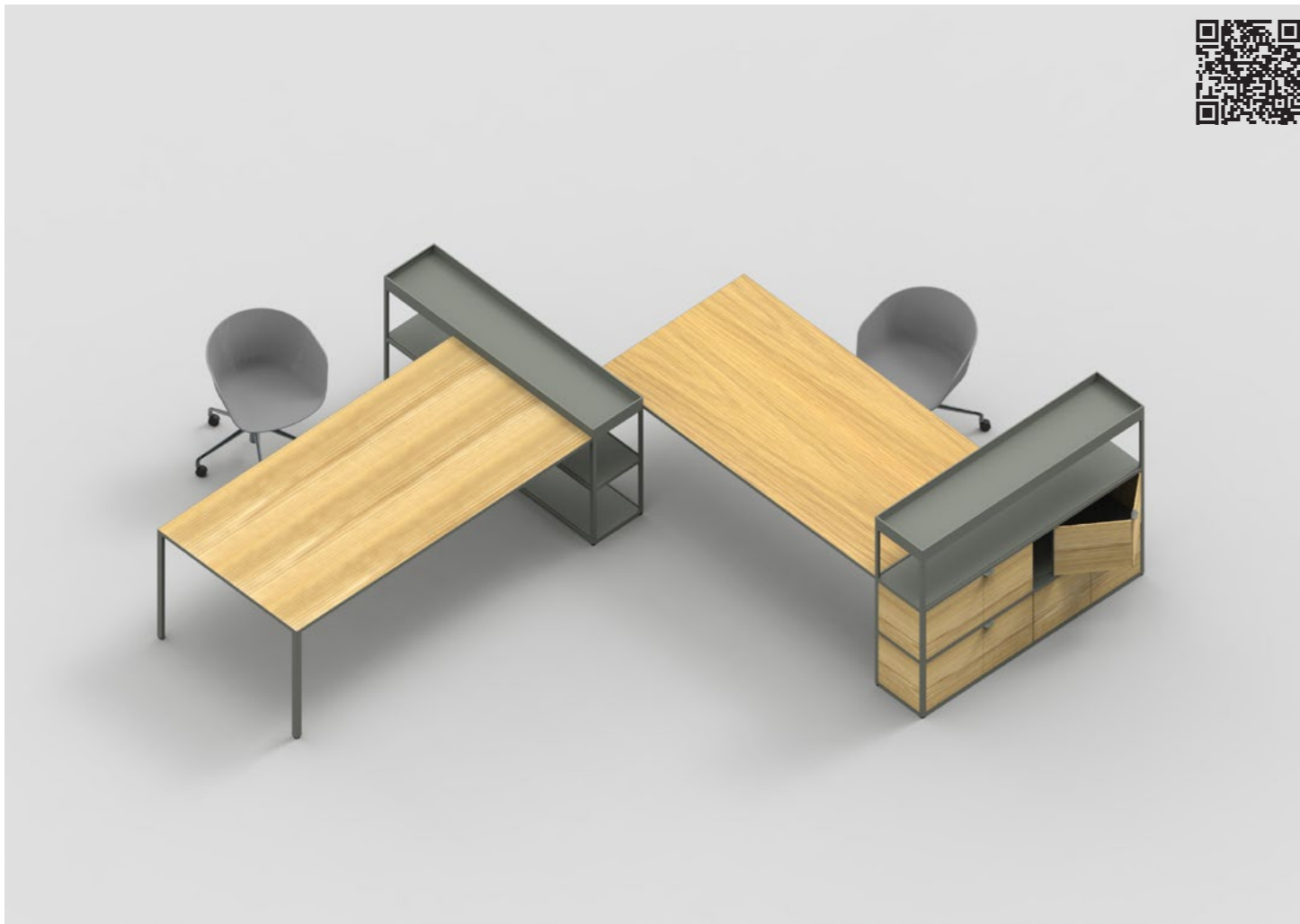



WALL-MOUNTED TABLE

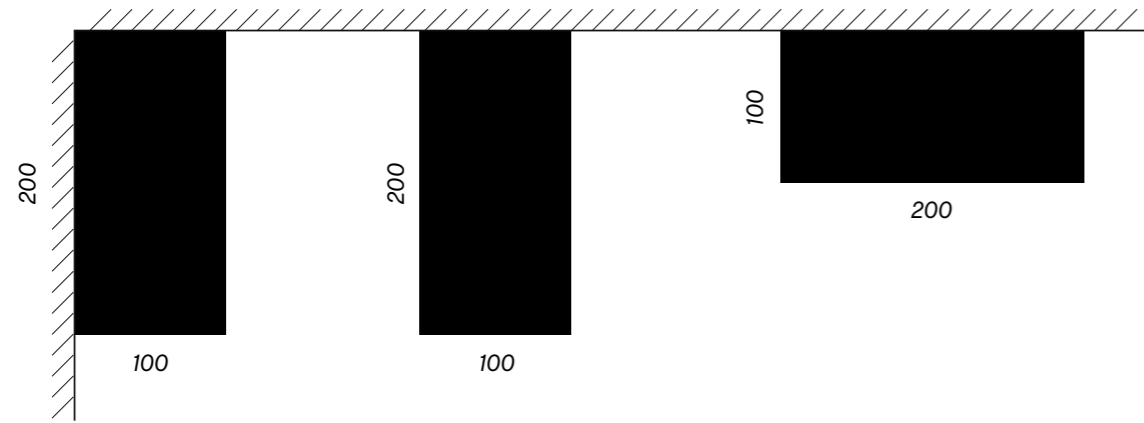

A special wall connector allows the tables to adapt to the given architecture, especially convenient if radiators or cable channels are blocking the space for the table legs.



UPHOLSTERY

CENTER ISLAND

BENCH, SHARED AREA, INFORMAL MEETING

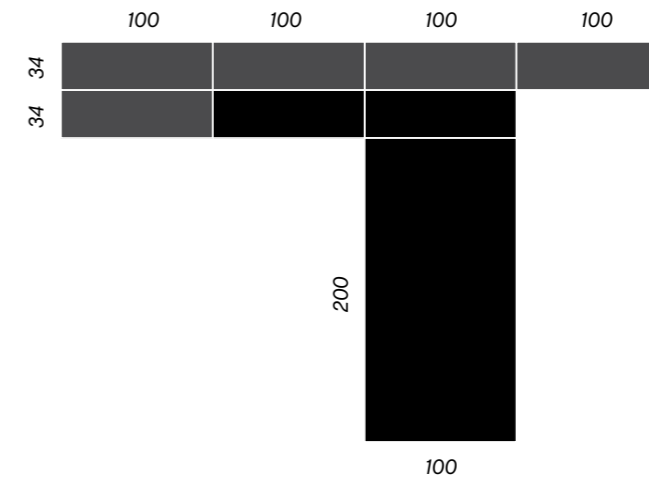

## SHELF-MOUNTED TABLE

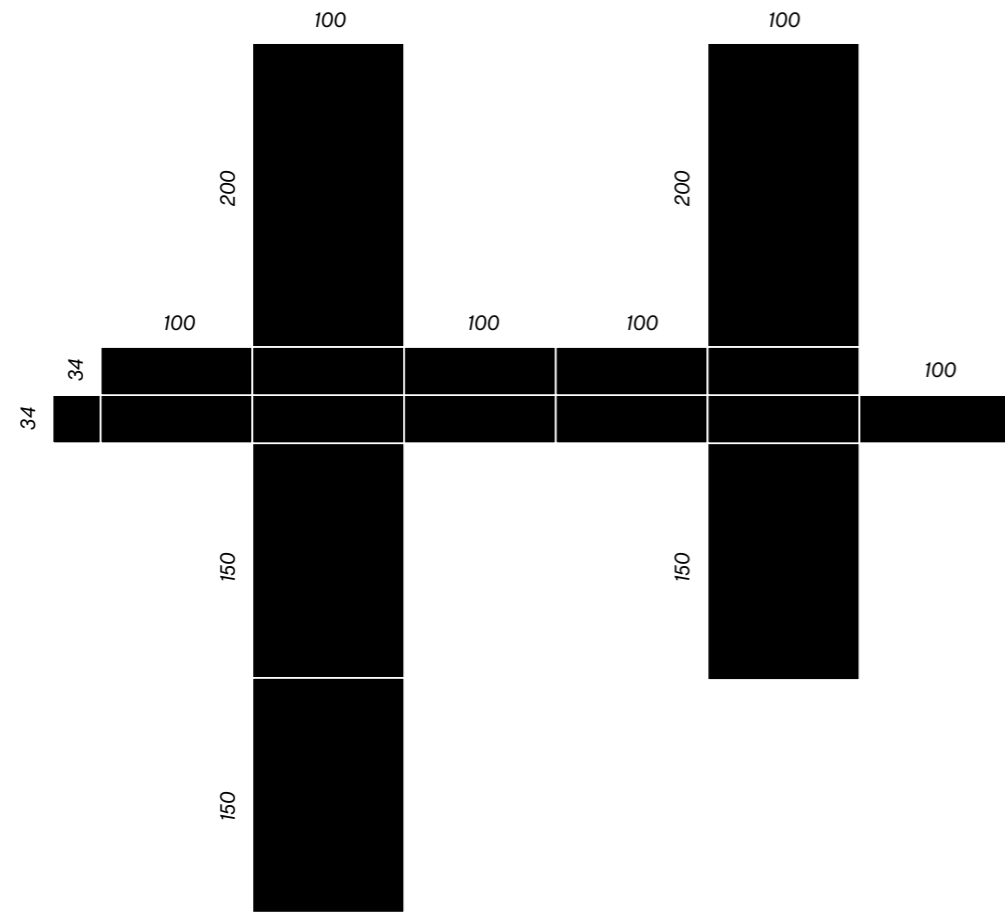

With the help of double and tripple spacers, New Order can develop out of a New Order wall or shelving unit, forming workstations independant from the given spacial situation.

## SHELF-MOUNTED WORKSTATION

SPACE DIVIDER, STORAGE, OPEN SHELVES, HIGH TABLE, PINBOARD WALL



TABLE-MOUNTED SHELF

LIBRARY / UNIVERSITY STUDY

INTEGRATED LIGHT BEAM

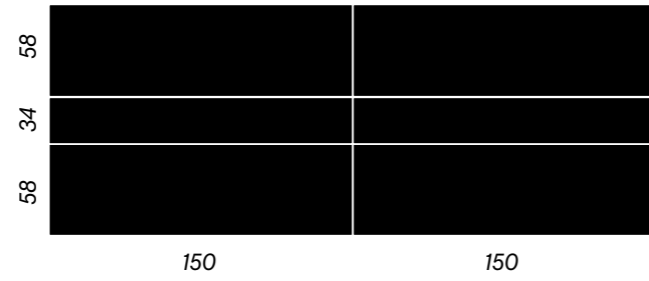

COMBINED WORKSPACE EXTENDED

SHARED UNIT, MULTIPLE HEIGHTS, STANDING WORKPLACE

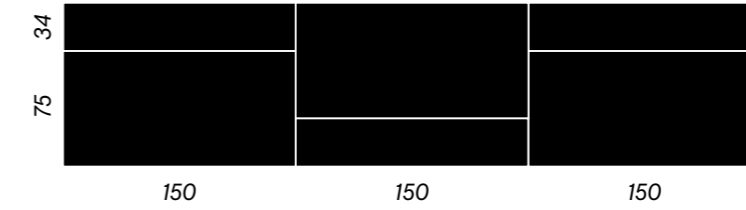

### RECEPTION COUNTER

COUNTER HEIGHT, INTEGRATED DESKS, DISPLAY, STORAGE, UNIDIRECTIONAL

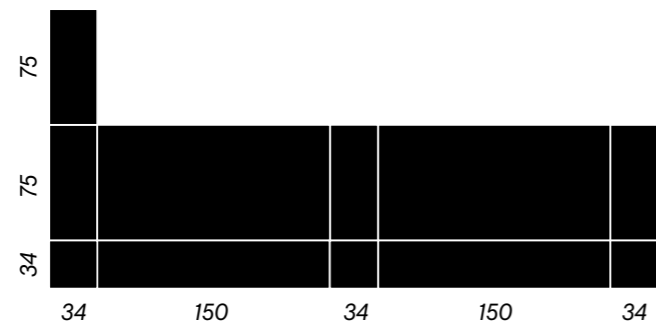

### ROLLS

#### TROLLEYS

PERSONAL STORAGE, CARRYING CART, FLEXIBLE SPACE DIVIDERS

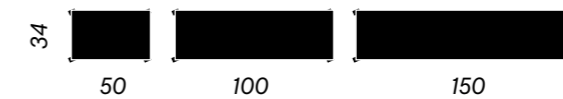

Rolls can replace the standard gliders on the bottom shelves/trays and can transform New Order setups into mobile units.



WORKSPACE UNITS

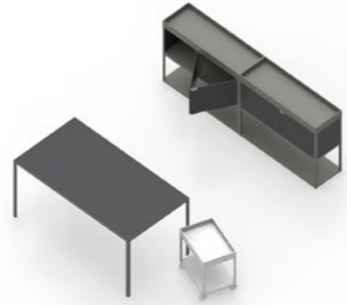

BASIC WORKSTATION



DEEP CABINET

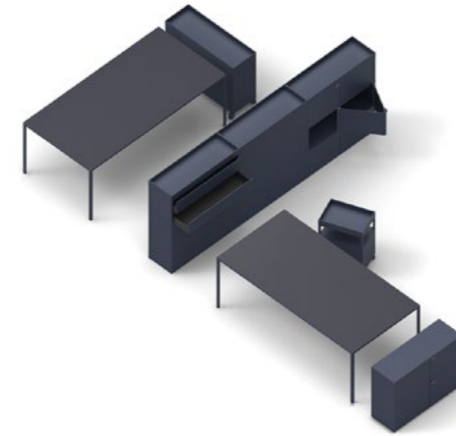

SINGLE WORKSTATIONS



SHARED DESK

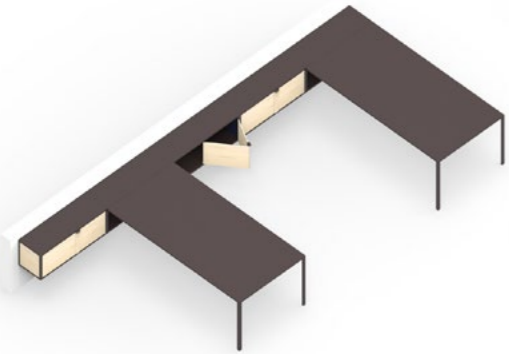

WALL-MOUNTED WORKSTATION



SHELF-MOUNTED WORKSTATION

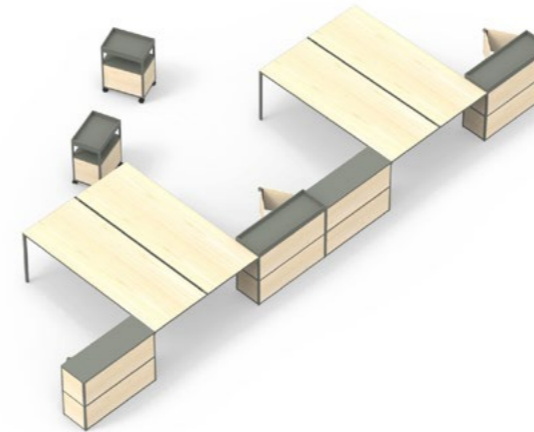

HOOKED DESK ROW

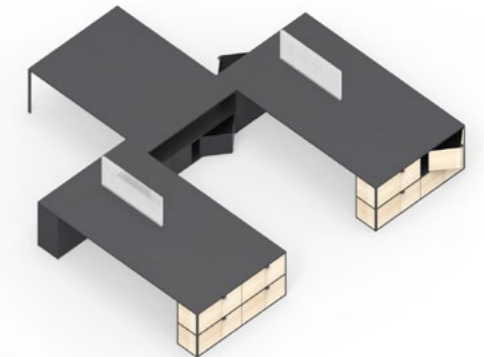

MULTI-DESK ISLAND, EXTENDED

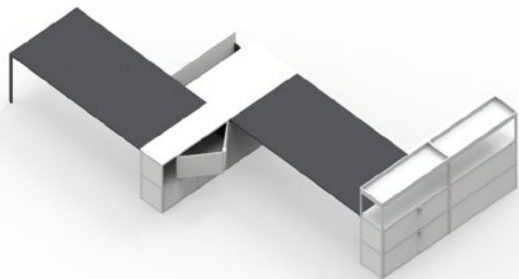

SHIFTED DESKS

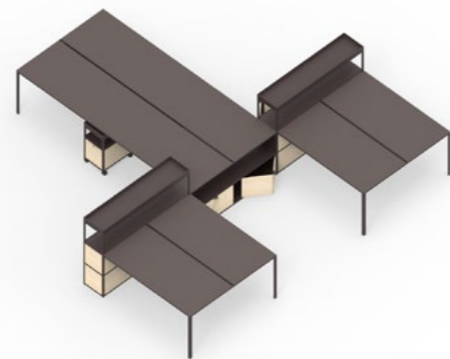

MULTI-DESKS ISLAND

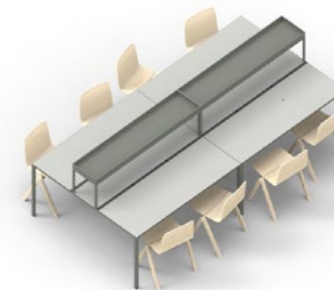

LIBRARY/UNIVERSITY STUDY

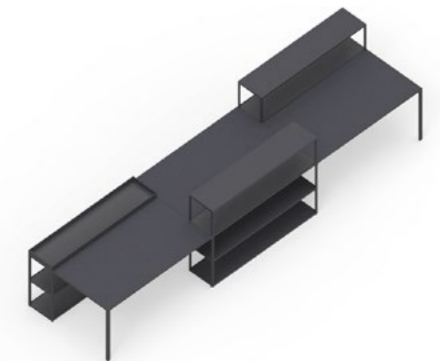

COMBINED WORKSPACE



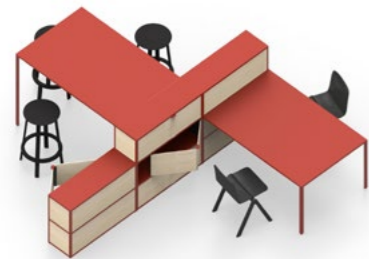

COUNTER ISLAND

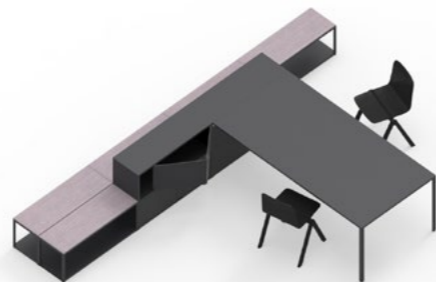

CENTER ISLAND



COUNTER



MEETING ISLAND

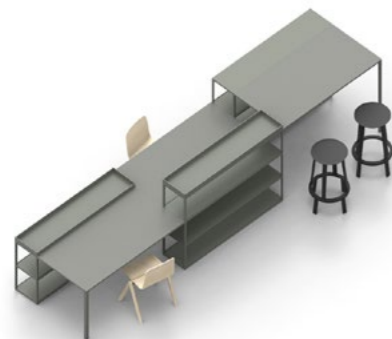

COMBINED WORKSPACE, EXTENDED

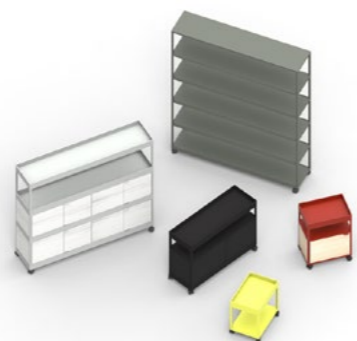

TROLLEYS / ROOM DIVIDERS

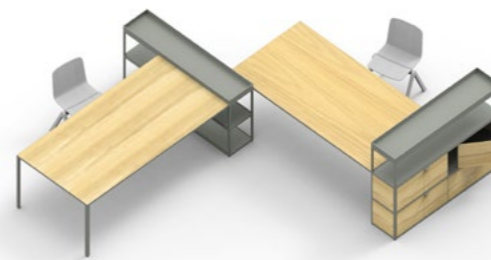

IRREGULAR WORKSTATION

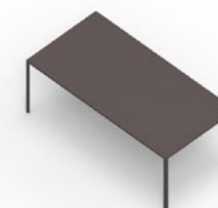

TABLE



RECEPTION COUNTER

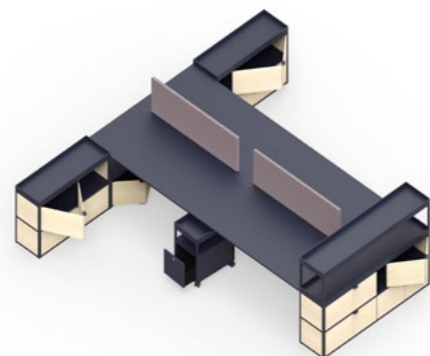

MULTI-DESK WORKSTATION



MEETING

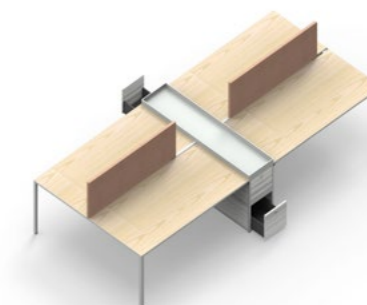

WORK UNIT



## CORK ACCESSORIES

*The trays are a perfect housing for smaller and larger objects. For this reason we have designed a family of cork accessories that perfectly sort smaller and precious utensils often in the proximity of the workspace. Their design offers the freedom to play with their position, depending on custom needs.*

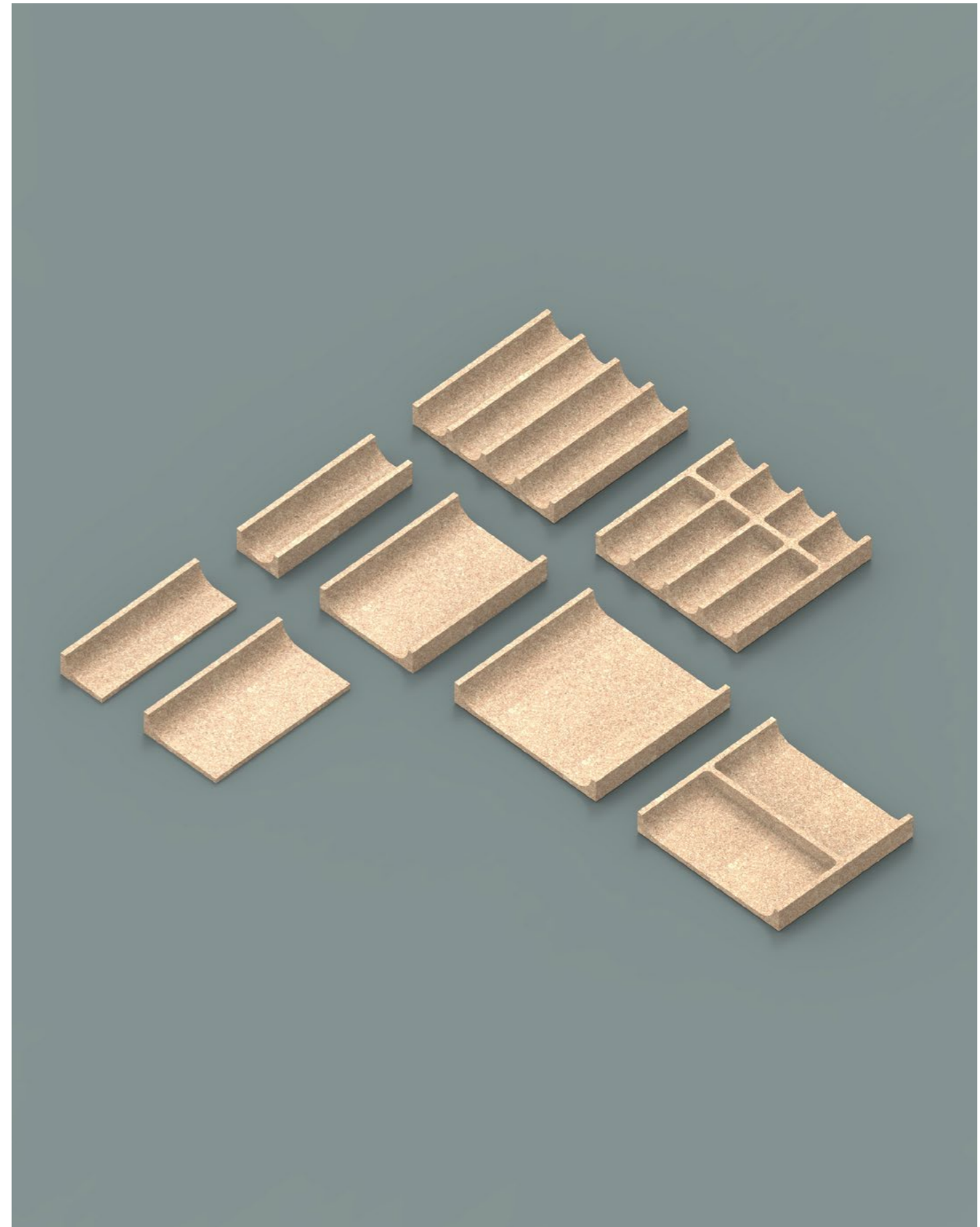





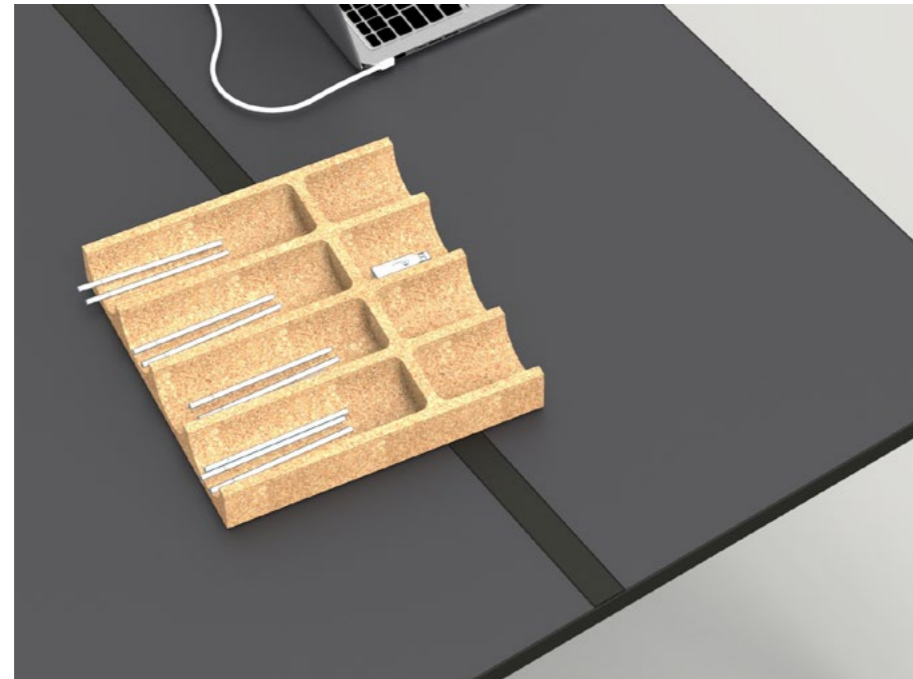

## BENT METAL ACCESSORIES

*These bent metal accessories are an obvious complement to the New Order shelves and trays, and will quickly become an essential component of the office.*

*Whether the shelves remain open, semi-closed by panels or completely closed by sliding doors, these accessories integrate perfectly into every piece. Thanks to a special feature, they self-lock themselves into position while remaining easily removable if need be. Offered also in bright colors, they amplify the usability of the shelves while intensifying the refined graphic aesthetic.*

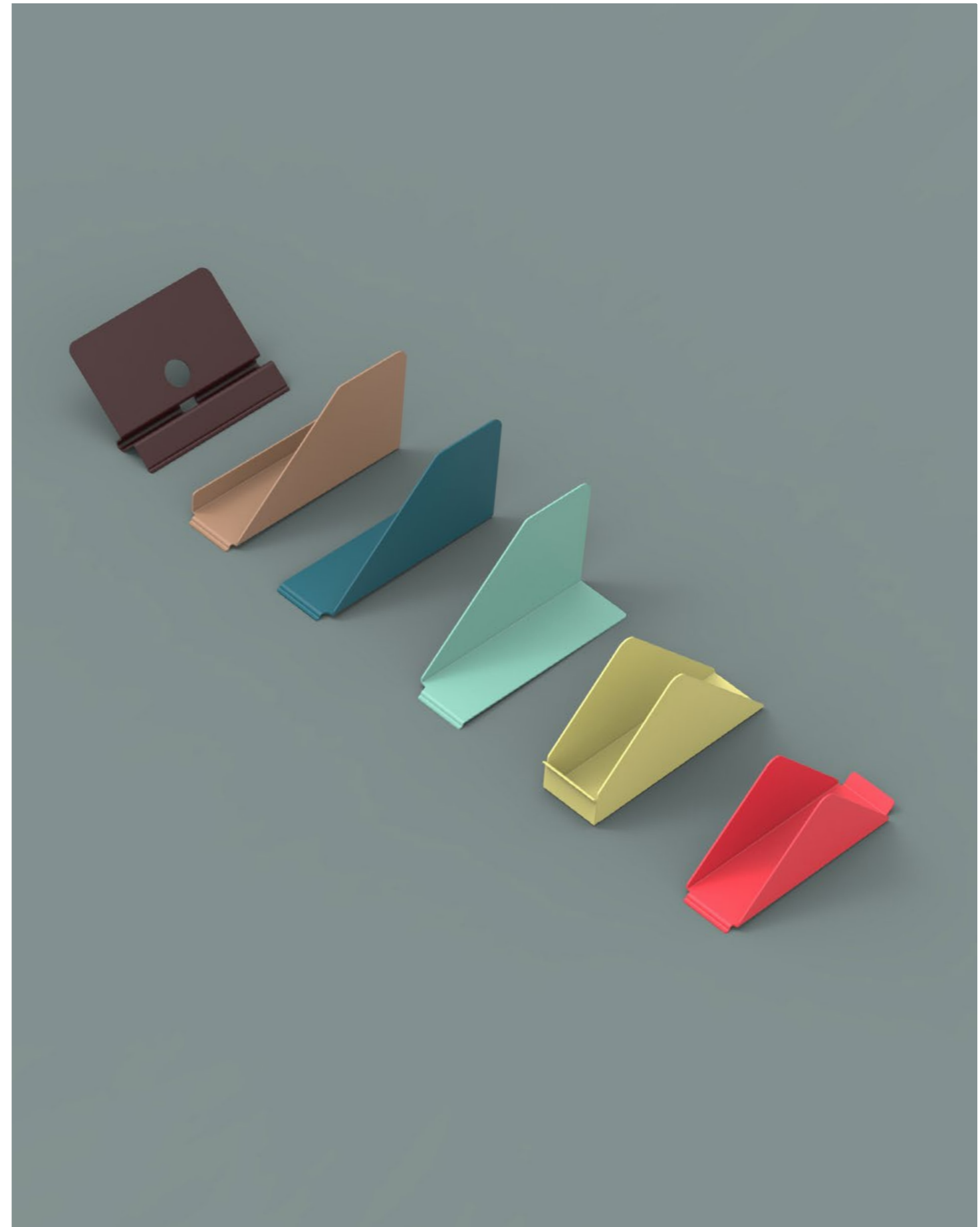





**Shelves**

front view

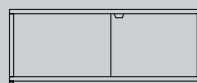

L100 X H38,5 cm



L100 X H50 cm

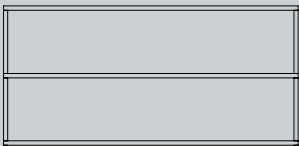

L150 X H74 cm

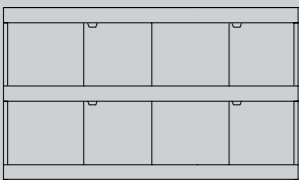

L150 X H91 cm



L200 X H79,5 cm



L300 X H79,5 cm

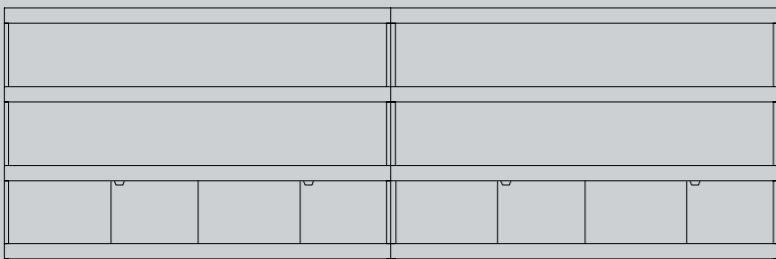

L400 X H132 cm

**Tables**

top view

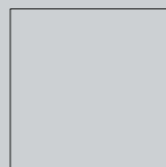

L100 X W100 cm

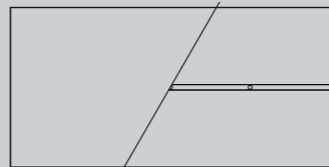

L200 X W100 cm

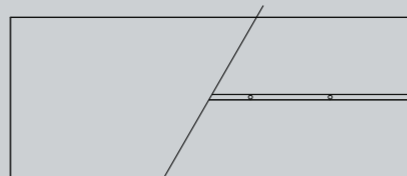

L250 X W100 cm

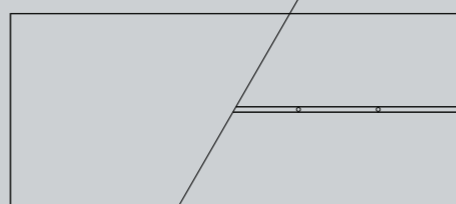

L280 X W120 cm

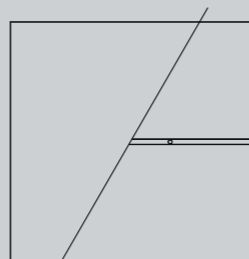

L150 X W150 cm

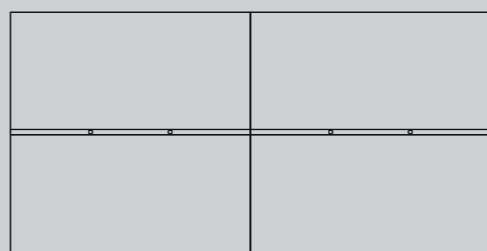

L300 X W150 cm



L--- X W34 cm  
Custom-made Length: from L34 to L200 cm



H--- cm  
Custom-made profile heights



H45 cm

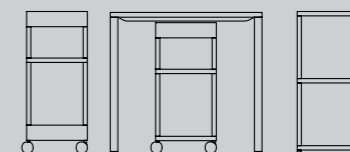

H68 cm



H74 cm

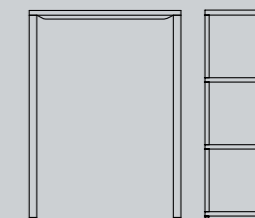

H110 cm



H38,5 cm



H44,5 cm



H50 cm



H74 cm



H79,5 cm



H110 cm



H115 cm



H132 cm



H250 cm



H255 cm

**Trays**

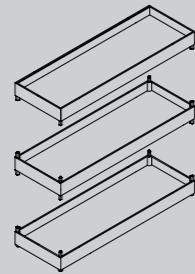

Tray, corner top, middle and bottom  
W34 X H8 cm



Tray, top, middle and bottom  
W100 X H8 cm

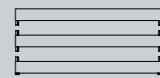

Tray, top, middle and bottom  
W150 X H8 cm



Tray, top, middle and bottom  
W200 X H8 cm



**Panels**

Set of 2 side panels + 1 back panel

Side panel (X2)  
L28 X H33 cm



Back panel 100  
L95 X H33 cm

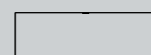

Back panel 150  
L145 X H33 cm



Back panel 200  
L195 X H33 cm



**Sliding doors**

Sliding right for 100 cm



Sliding left door for 100 cm



Sliding door for 150 cm



Sliding door for 200 cm



**Shelves**

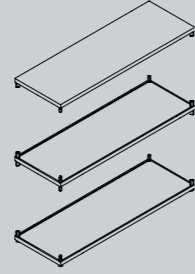

Shelf, corner top, middle and bottom  
W34 X 2,3 cm



Shelf, corner top, middle and bottom  
W100 X 2,3 cm

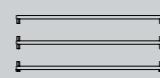

Shelf, corner top, middle and bottom  
W150 X 2,3 cm

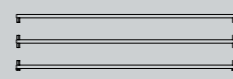

**Profiles**

Single profile set (X4) H33 cm



Double profile connector set (X2) H33 cm



Corner profile connector set (X1+1 single profile) H33 cm



**Wall brackets / Wall panels**

Wall bracket set (X2) L6 X H33 cm



Wall bracket Tray set (X2) L6 X H39 cm



Wall panel 100 L95 X H33 cm

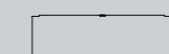

Wall panel 150 L145 X H33 cm



Wall panel 200 L195 X H33 cm

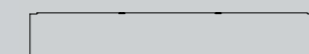

**Tables**

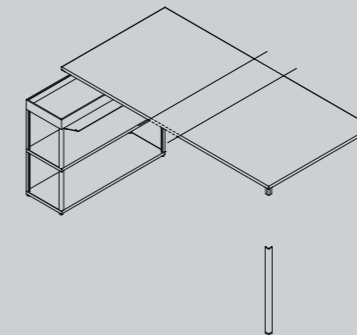

Table top, with or without leg pin



Custom-made legs heights



Legs, Double Legs, Triple Legs H72 cm



Legs, Double Legs, Triple Legs H108 cm



**Cork Accessories**

L-Shape, size S



L-Shape, size M



U-Shape, size S



U-Shape, size M



**Bent Metal Accessories**

Tray Book divider



Shelf Book divider



Shelf Book divider with stopper



Shelf Book display



U-Shape, size L

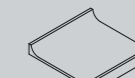

U-Shape, size L with separation



WW-Shape, size L

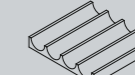

WW-Shape, size L with separation

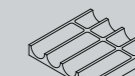

Frame,  
powder-coated  
aluminium



Army



Chocolate



Light grey



Yellow



Red



Charcoal

Panels and  
sliding doors,  
veneer

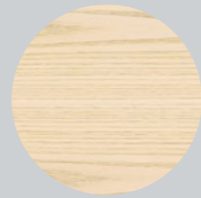

Ash



Oak



Charcoal



Light grey

Table tops,  
veneer



Ash



Oak

linoleum

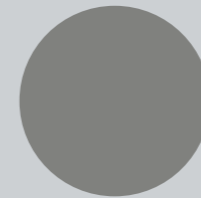

Ash

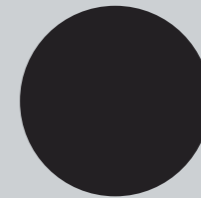

Charcoal



Carbon

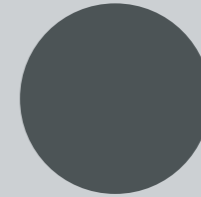

Pewter

powder-coated  
mdf

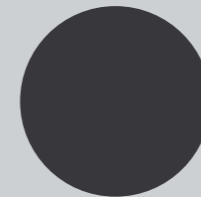

Charcoal

laminated  
mdf



Light grey



Copyright / Nine United Denmark A/S 2014  
Main photos / Rasmus Norlander  
Additional photos and renderings / Stefan Diez Office  
Cover art direction / Mirko Borsche  
Graphic design / Jonathan Mauloubier  
Proof-reading / Alison Wade  
Text / Charlotte Jul and Stefan Diez

Subject to printer's errors

[www.new-order.info](http://www.new-order.info)  
[www.hay.dk](http://www.hay.dk)

